



**Total Door** SYSTEMS™  
Global Leader in Integrated Access Technology™

# OWNER'S MANUAL®



**Total Door** SYSTEMS™  
Global Leader in Integrated Access Technology™

## **OWNER'S MANUAL**

Total Door Systems® is an integrated system of door body, hardware and accessories. Total Door Systems®, together with its distributor network, offers single source responsibility for ADA and code compliance systems including installation and service.

For successful operation of the Total Door, it is necessary that the individual parts of the systems work in harmony. Each door is bench tested at the factory for proper operation prior to packaging and shipment. A door that does not pass the bench test is corrected or rebuilt.

The Installation Key will be of help to you in identifying any service problems that you may encounter. Use it in conjunction with Tech Data Sheet #36 which is in Section IV of your manual.

To ensure that you will continue to enjoy the benefits of our product for many years, we want you to know about the Service Seminars that are offered at the factory. These seminars provide an in depth coverage of installation, service and repair issues. Please check our website for seminar schedule and to sign up. <http://www.totaldoor.com/> The cost of the meals and lodging are covered and the seminar is offered at no charge. Transportation costs are not covered.

If you would like further information or technical support, please contact Total Door Systems' Service Department at 248-623-6899.

# Total Door Systems® Owner's Manual

## Section I

Parts List	Page
Drawing - Latch Side	1-1
Parts List - Latch Side	1-2
Drawing - Lever Mechanism	1-3
Parts List - Lever Mechanism	1-4
Drawing - Push-Pull Mechanism	1-5
Parts List - Push-Pull Mechanism	1-6
Drawing - Panic Exit Device	1-7
Parts List - Panic Exit Device	1-8
Drawing - Flush Panic Exit Device	1-9
Parts List - Flush Panic Exit Device	1-10

## Section II

Installation Information	
Total Door Pre-Installation Checklist	2-1
Total Door Installation Instructions	2-2
Latch Stop	2-7
Pair of Doors	2-8
Double Egress Doors	2-9
Removable Mullion	2-10
Lever Mechanism Trim	2-11
Push-Pull Mechanism & Trim	2-14

## Section III

Trouble Shooting	
Latch Side	3-1
Hinge Side	3-3
Hanger Rod	3-4
Grips	3-5
Key Cylinder	3-7

## Section IV

Index & Technical Data Sheets
-------------------------------

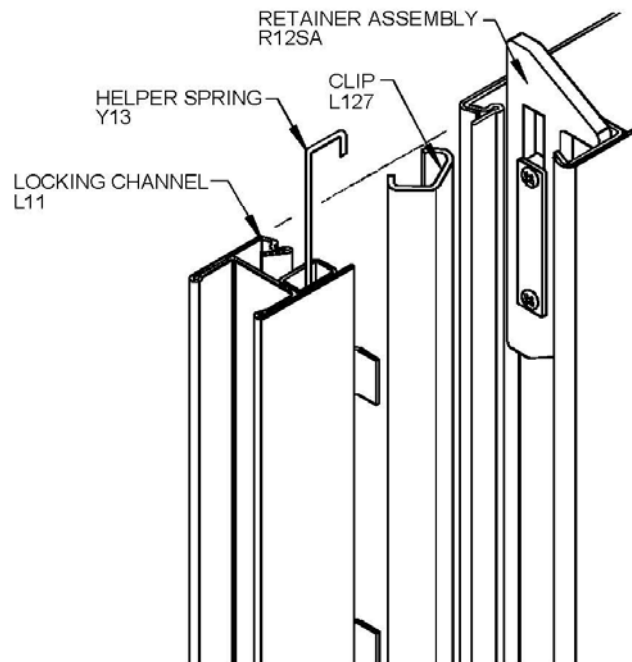
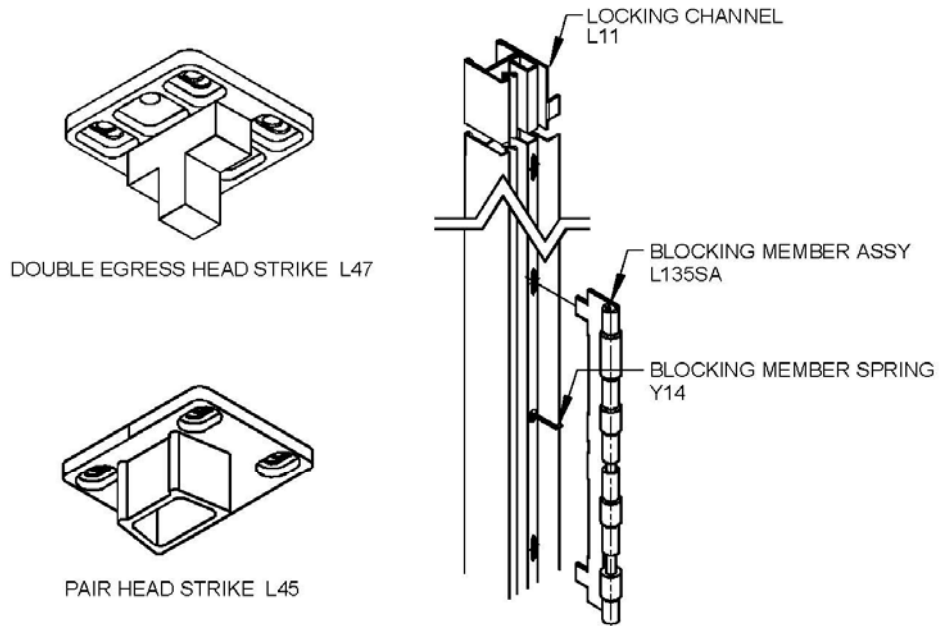

## Latch Side Parts



## **LATCH SIDE PARTS**

<b>PART NAME</b>	<b>PART NUMBER</b>
Locking Channel Assembly	L11SA
Blocking Member Assembly	L135ASA
Blocking Member Spring	Y14
Locking Channel Clip	L127
Helper Spring	Y13
Retainer Assembly	R12SA
Latch Stop (single doors)	L55
Latch Stop & Head Stop buttons (10 pack)	Y51
Latch Stop & Head Stop screws (100 pack)	X18
Head Strike – Pair (includes screws)	L45SA
Head Strike – Double Egress (includes screws)	L47SA

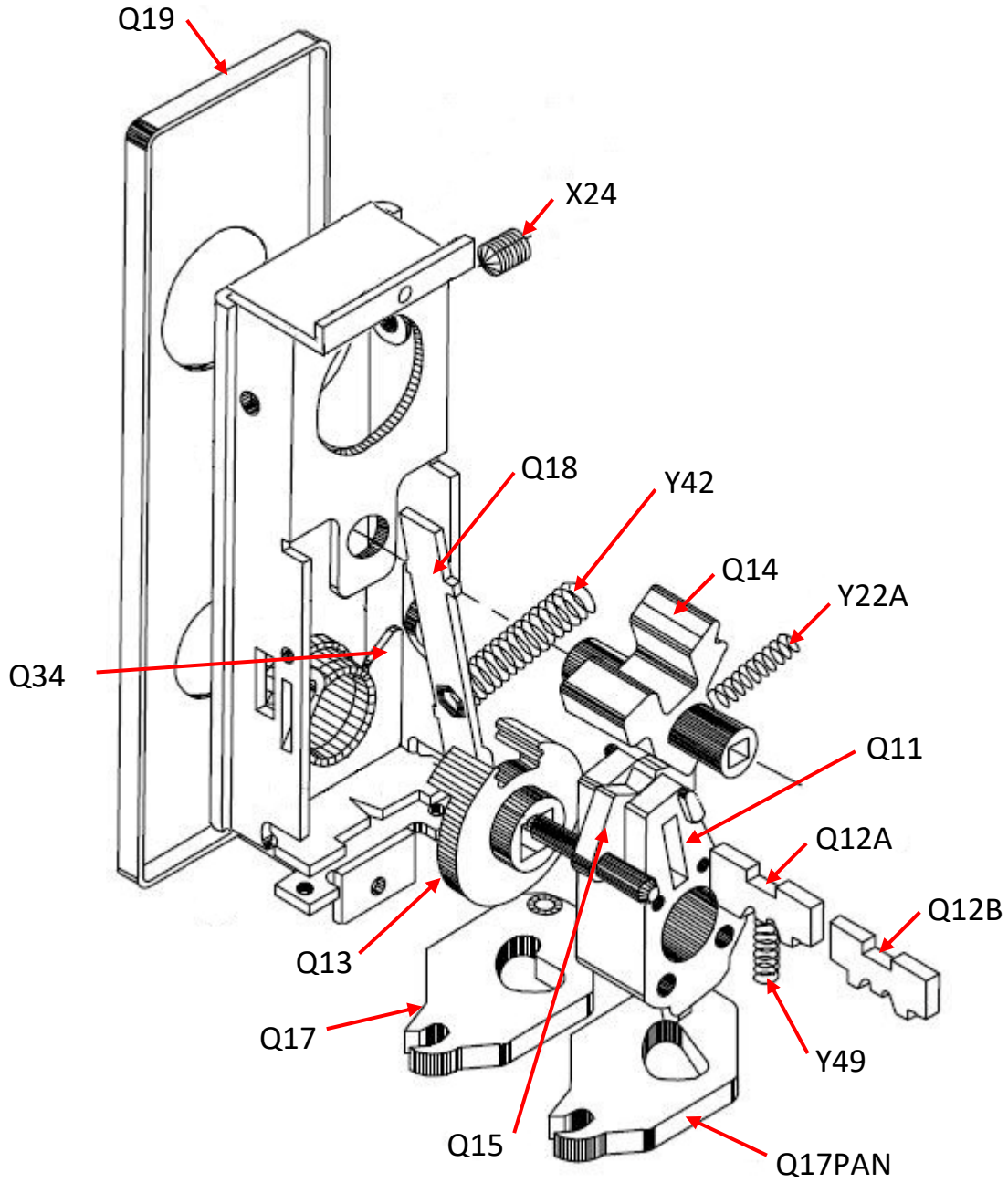

## Lever Mechanism Assembly

## **LEVER MECHANISM ASSEMBLY**

<b>PART NAME</b>	<b>PART NUMBER</b>
<b><u>LOCK MECHANISM</u></b>	
Actuator – Lever x Lever	Q17
Actuator – Lever x Panic/Flush Panic	Q17PAN
Cam	Q15
Clutch Housing	Q11
Dog – Single	Q12A
Dog – Double	Q12B
Dog spring	Y49
Escutcheon	Q19
Hub	Q13
Hub Stop	Q34
Lever Spring	Y42
Pan Head Screw	X21
Roll Pin	Y12
Set Screw	X24
Spring on Clutch Housing	Y22A
Spring Lever (handed)	Q18
Starlock Washer (Panic & Flush Panic)	X41
Turnpiece Hub	Q14
Spindle Assembly	Y44SA

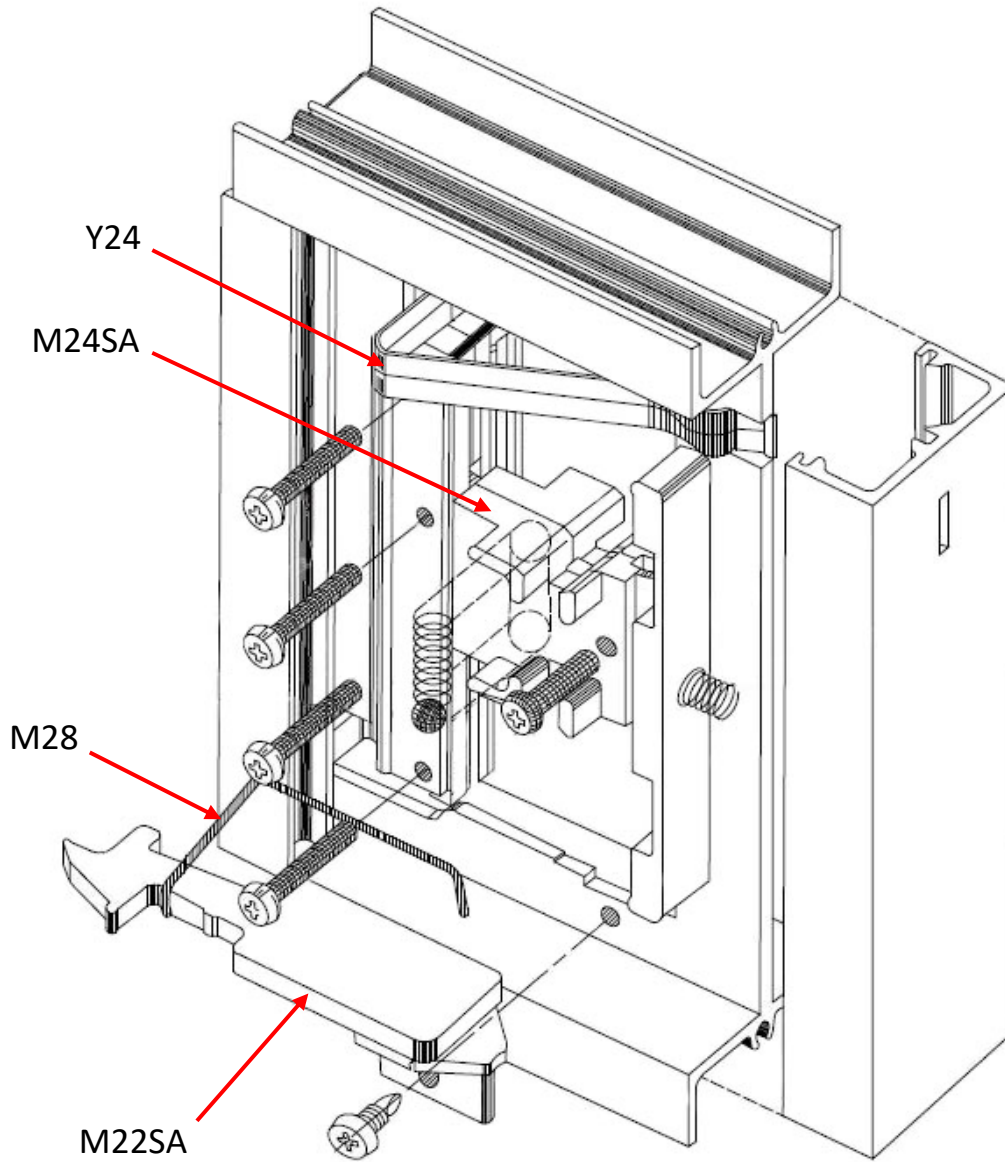

## Grip Mechanism Assembly

## **GRIP MECHANISM ASSEMBLY**

<b>PART NAME</b>	<b>PART NUMBER</b>
Actuator Assembly	M22SA
Slide Block Assembly (includes screws, slide block springs, ball bearing & locking bar)	M24SA
Puller Rod	M27
Face Spring	Y24

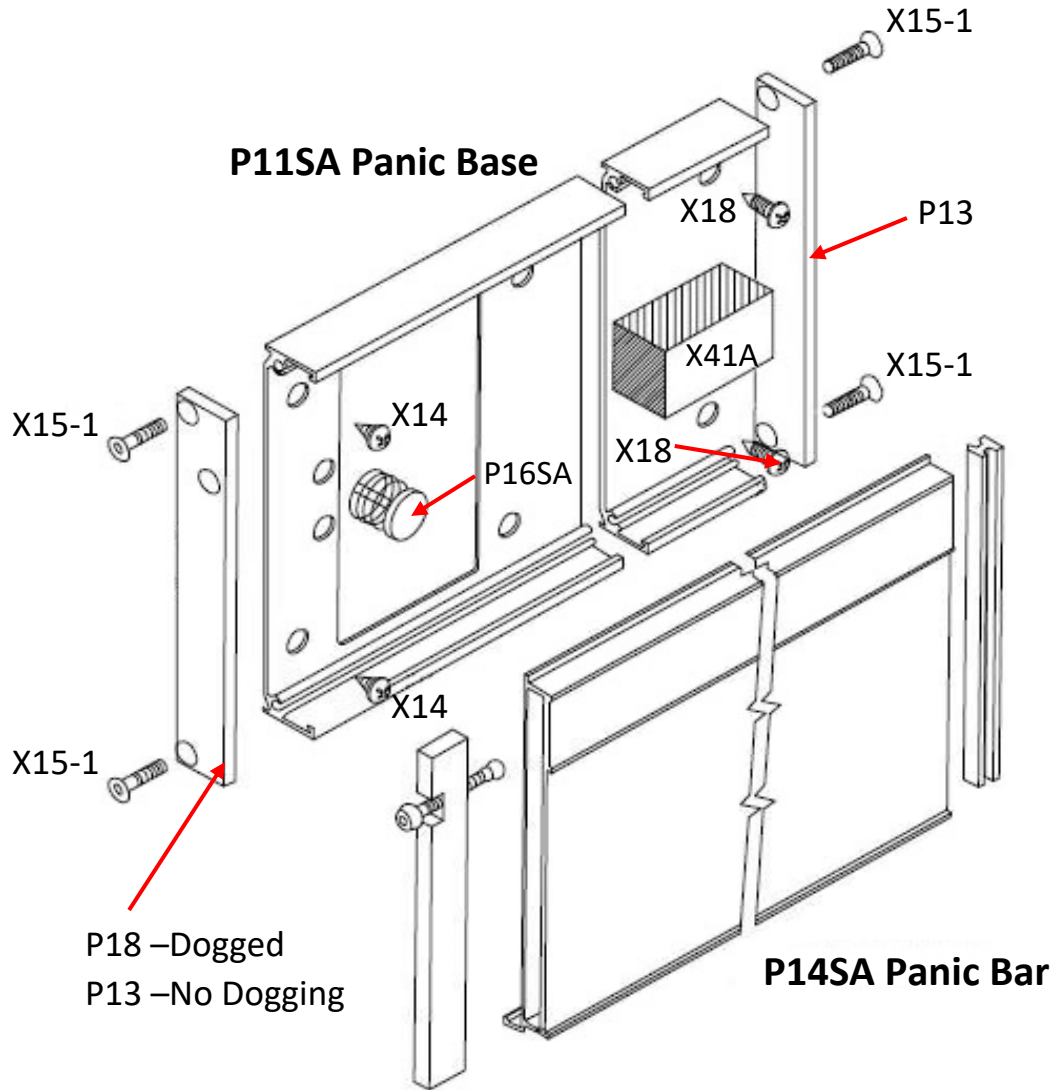

## P14/P14STP Panic Exit Device

## **PANIC, P14/P14STP EXIT DEVICE**

<b>PART NAME</b>	<b>PART NUMBER</b>
Panic Bar Assembly	P14SA
Panic Base	P11SA
Panic Button Assembly	P16SA
Base End Plate (includes screws)	P13
Base End Plate – Dogging (includes screws)	P18
Screws for base end plate	X15-1
Screws for Panic Base – latch side (2 ea.)	X14
Screws for Panic Base – mid & hinge side (4 ea.)	X18
Panic Foam	W41A

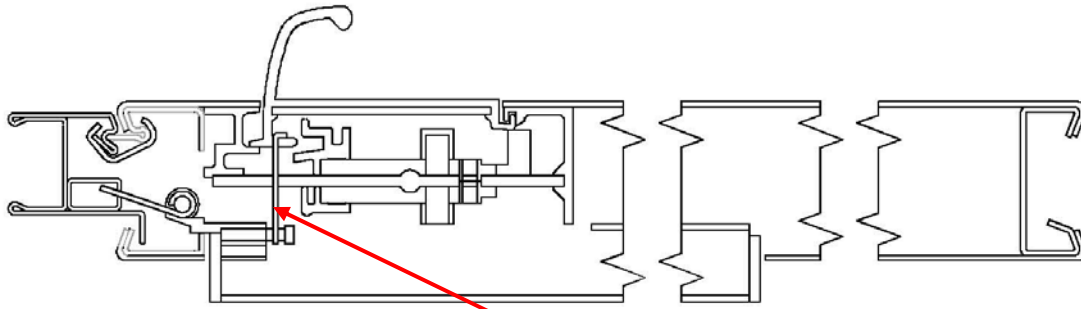

PF225, PULLER ROD  
(GRIP ONLY)

FLUSH PANIC END CAP  
WITH ACTUATOR  
PF201SA-L-GR/PEO

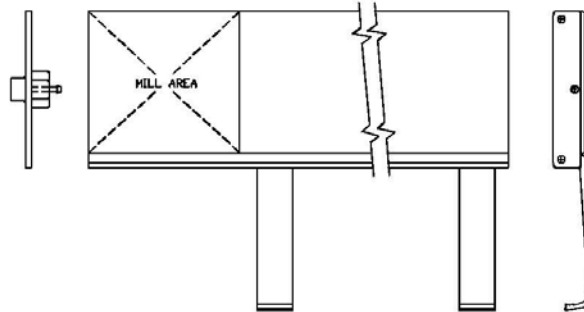

FLUSH PANIC BAR WITH GRIP – PF204SA-GR

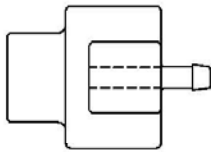

FLUSH PANIC ACTUATOR – GRIP/PEO  
PF221BSA

FLUSH PANIC END CAP  
WITH ACTUATOR  
PF201SA-L-LEV

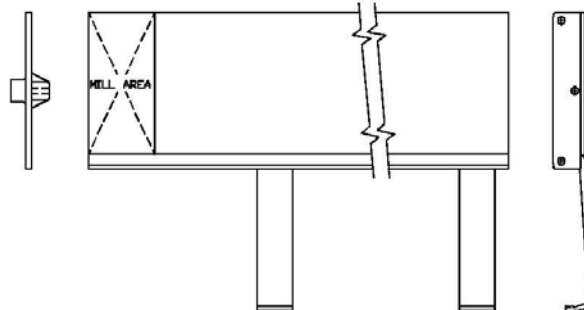

FLUSH PANIC BAR WITH LEVER – PF204SA-LEV

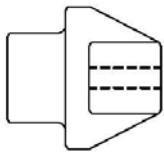

FLUSH PANIC ACTUATOR – LEVER  
PF221B-1SA

FLUSH PANIC END CAP  
WITH ACTUATOR  
PF201SA-L-GR/PEO

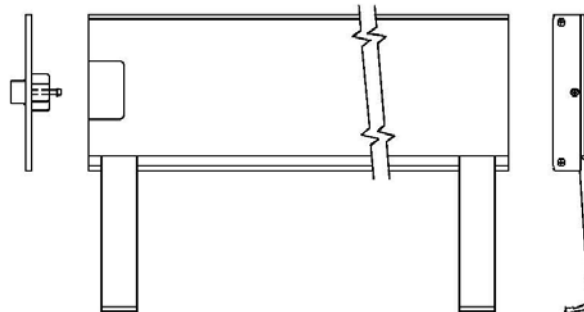

FLUSH PANIC BAR EXIT ONLY – PF204SA-PEO

## PF200 Flush Panic Exit Device



## **FLUSH PANIC, PF200 EXIT DEVICE**

<b>PART NAME</b>	<b>PART NUMBER</b>
End Cap w/ actuator Hinge Side (includes screws)	PF201SA=H
End Cap w/ actuator Latch Side (includes screws)	PF201SA=L
Panic Bar – PEO	PF204SA-PEO
Panic Bar – Grip	PF204SA-Grip
Panic Bar – Lever	PF204SA-Lev
Actuator for Grip (includes screw)	PF221BSA
Actuator for Lever (includes screw)	PF221B-1SA
Puller Rod (Grip only)	PF225
Face Spring (Grip only)	PFY24
Slide Block Assembly	PFM24SA
Flush Panic end cap (button)	Y96

# Installation Information

Pre-Installation Checklist	2-1
Installation Instructions	2-2
Latch Stop	2-7
Pair of Doors	2-8
Double Egress Doors	2-9
Removable Mullion	2-10
Lever Mechanism Trim	2-11
Push-Pull Mechanism and Trim	2-14

# Total Door Systems® Pre-Installation Check List

Total Door Systems® should never be installed in a frame that is not within stated tolerances.

Installed incorrectly or in a frame that is not within stated tolerances becomes the installer's responsibility. It is not covered by the Total Door Systems® Performance Warranty.

Thus, it is especially important in both replacement/renovation projects and new construction that frames be checked for size, straightness, and plumbness.

Field adjustments, including re-setting the frame, should be complete prior to installation.

Total Door Systems® Dimensional Tolerances: (Note: These tolerances should never be exceeded)

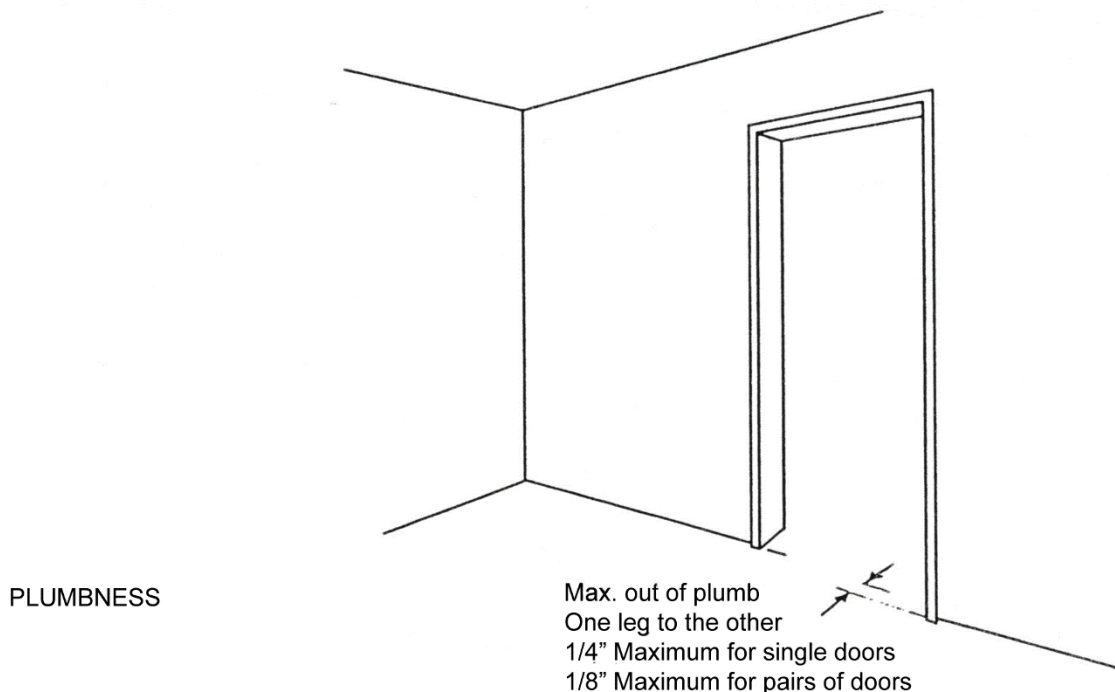
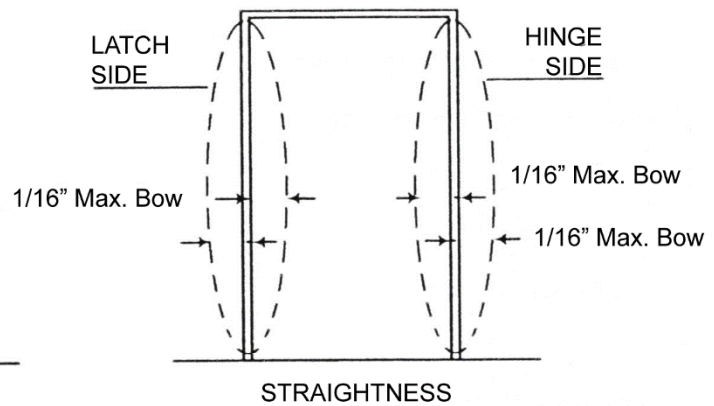
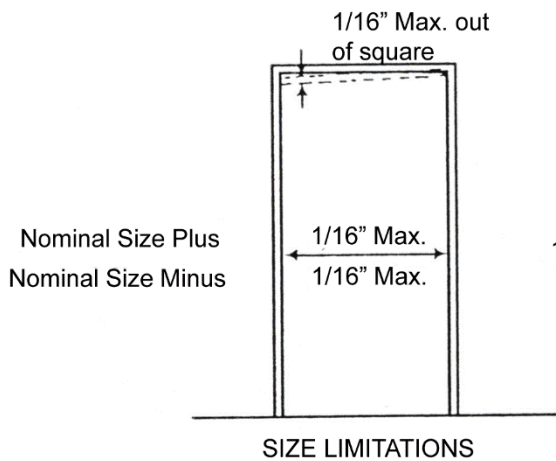

# Total Door Systems® Installation Instructions

## HINGE SIDE

1. Pry out hinge block, H-15.
2. Hinge housing, H-12, may now be removed.
3. Make certain hinge block, H-14, and hinge, H-13, remain securely seated in door stile.

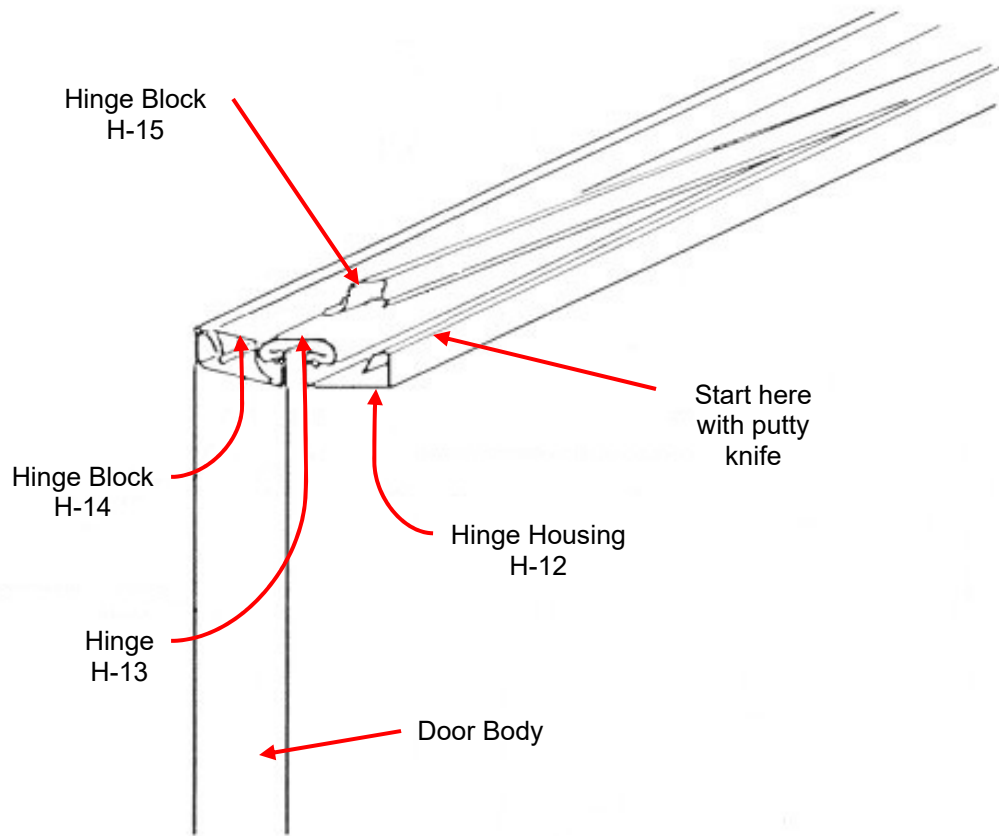

### **NOTE:**

Use putty knife only to begin removal of hinge block, H-15. Use prying action of fingers along full length "ROLL" out the H-15. Do not strip out or rip out the H-15, as this will deform the member.

4. Place hinge housing, H-12, flat against jamb and  $1/16''$  from frame head, with notch on the pull side. Allow  $5/32''$  clearance between H-12 and rabbet (In a cased opening, H-12 may be flush to  $1/16''$  from edge of jamb on pull side). Use installation key, which is provided, to insure proper tolerances.
5. Hold hinge housing, H-12, in position and install 3 #10 Tek (X-65) screws, one at the top ROUND hole, one in the middle slot, and one at the bottom slot. The Tek screws, which are installed in the middle and bottom slots, should be at the bottom portion of those slots.

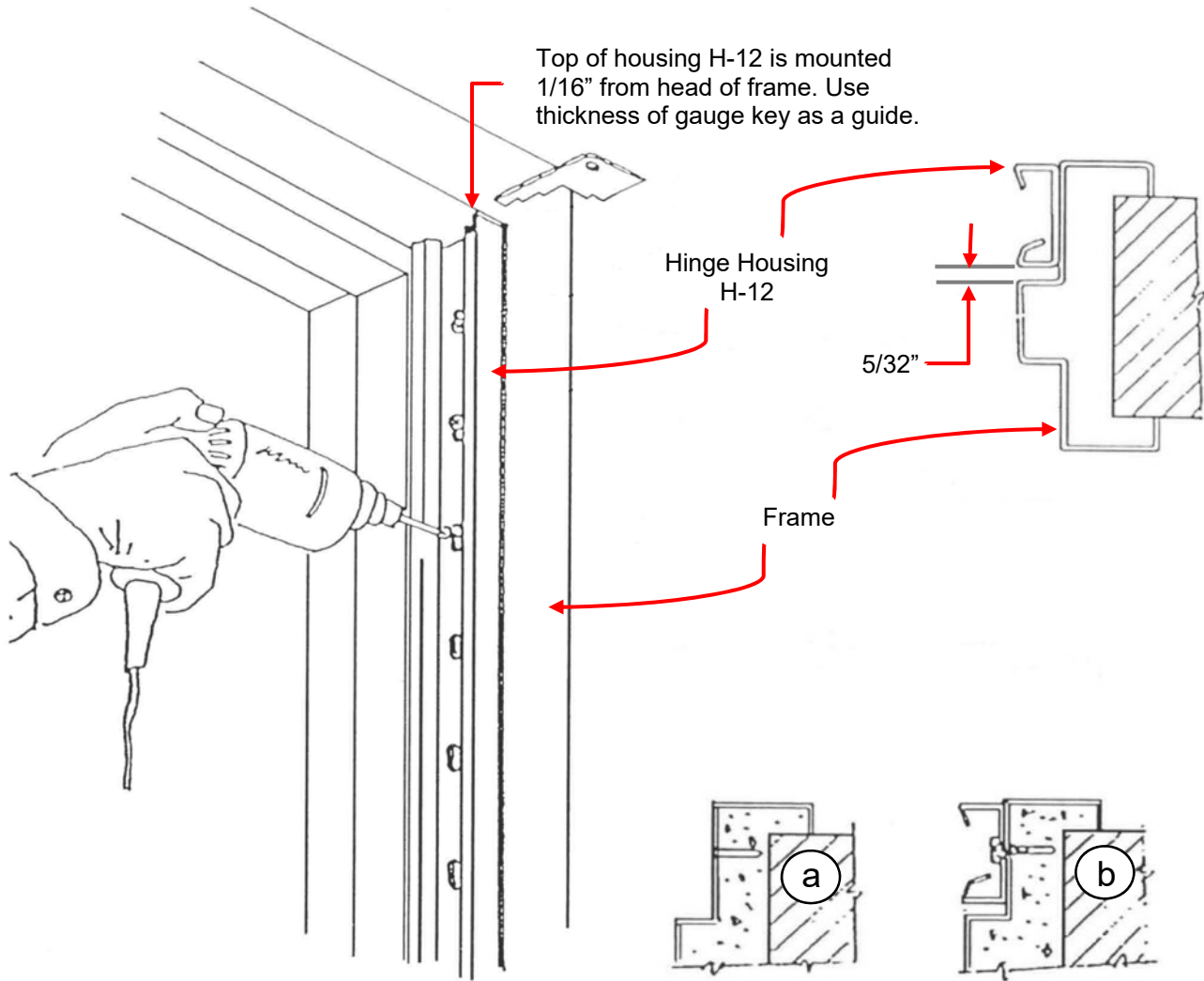

We have found the following procedure for installation to be fast, secure, and economical.

- a) Use a  $1/8''$  masonry drill bit to drill holes  $3/4''$  deep.
- b) Install the 3 #10 Tek (X-65) screws supplied with the door.

6. Stand door up. Place it at approximately 30° angle to the door jamb at the hinge housing, H-12.
7. Tilt hinge side of door upwards\* to facilitate seating the top hook of the hanger rod in the rectangular slot in the top of the hinge housing, H-12.
8. Insert lower hook of stainless steel hanger rod in the rectangular notch on the pull side of the door stile about 24" from the top of the door. The door is now suspended from the frame by the hanger rod.

\*When tilting the door, the space between the top of the door and the jamb, **SHOULD NOT** exceed 6"

This can cause hanger rod failure

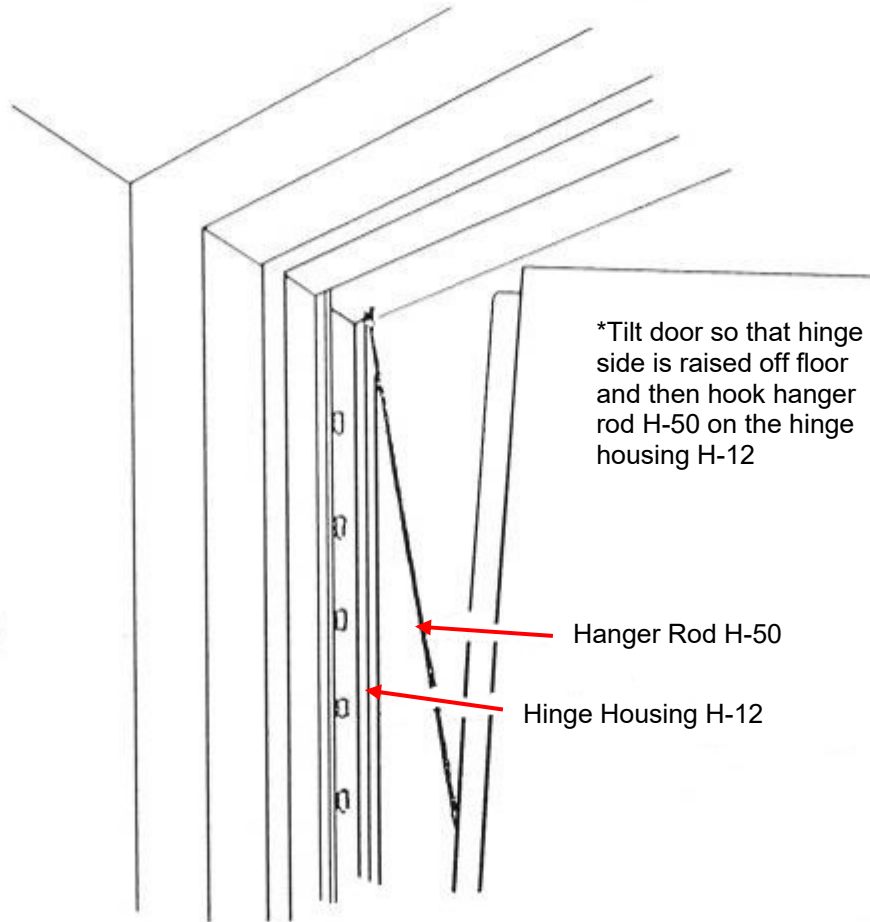

\*Tilt door so that hinge side is raised off floor and then hook hanger rod H-50 on the hinge housing H-12

Hanger Rod H-50

Hinge Housing H-12

**NOTE:**

See Technical Data Sheet #40B for installation of H-50.

9. Lift the latch side of the door so that the hinge side is vertical and parallel to the hinge housing, H-12.
10. Move the door towards the hinge housing, H-12, mounted on the jamb and engage the bulb of the hinge, H-13, inside the near lip of the hinge housing, H-12.

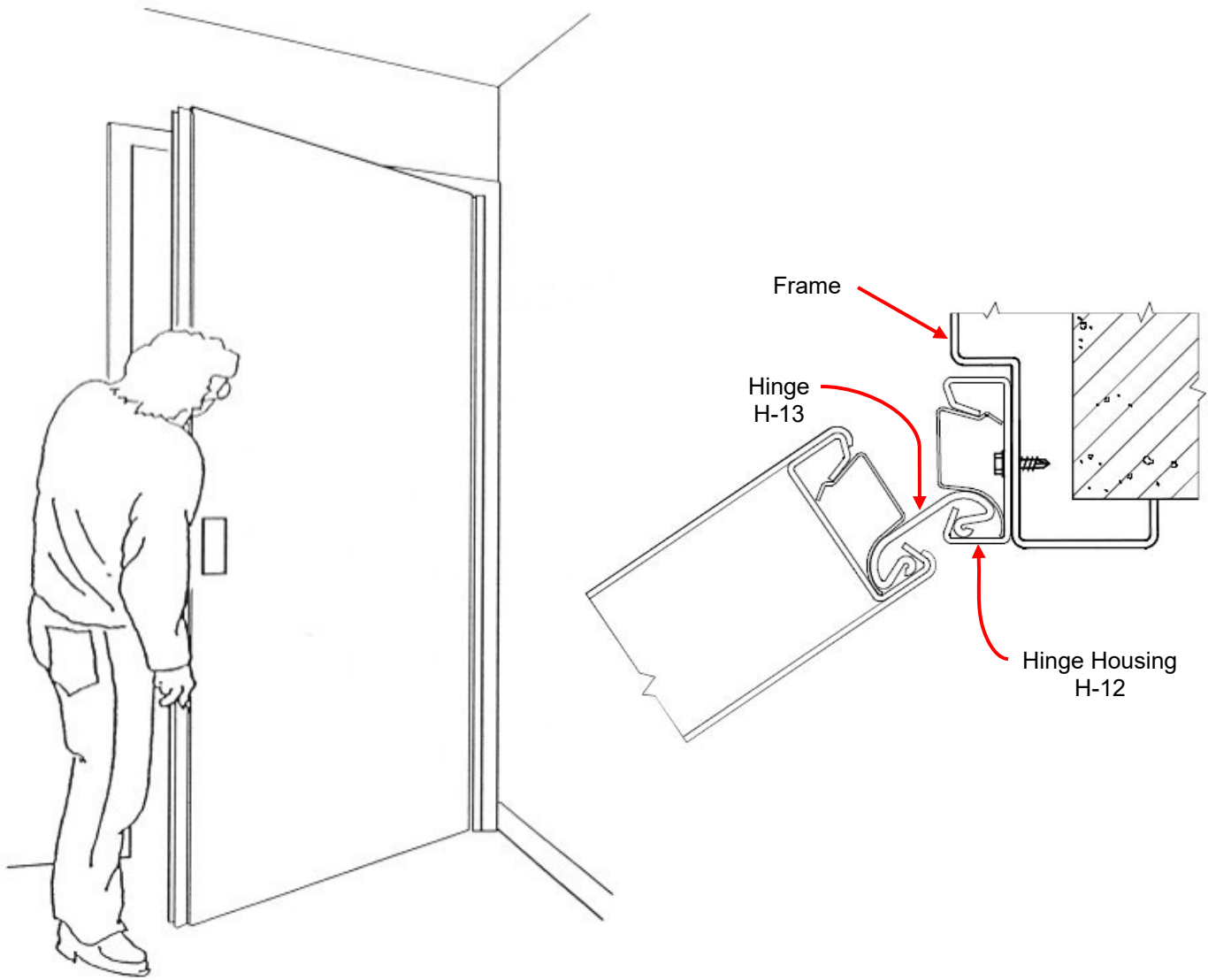

11. Assure the bulb of the hinge, H-13, remains securely seated inside the lip of the hinge housing, H-12, by opening the door to its maximum open position. Use the short sections of hinge block material supplied with your parts and snap them into place. This secures the door in the frame while allowing the door to be adjusted either up or down. If there is an adjustment to be made to allow the door to fit in the opening, remove the top screw from the round hole and loosen the middle and bottom screws. Slide the hinge housing as required and re-secure the top screw in the new hole. Tighten middle and bottom screws. Once the door is in the proper location in the opening, install the remaining 12 Tek screws in the remaining slots for a total of 15. Take out the short sections of hinge block material used for adjusting and snap the hinge block, H-15, into place along the full length of the door — starting at the top without deforming the hinge block (if more than hand force is required, use only a rubber mallet, do not use a hammer or other hard object). The door is now installed.

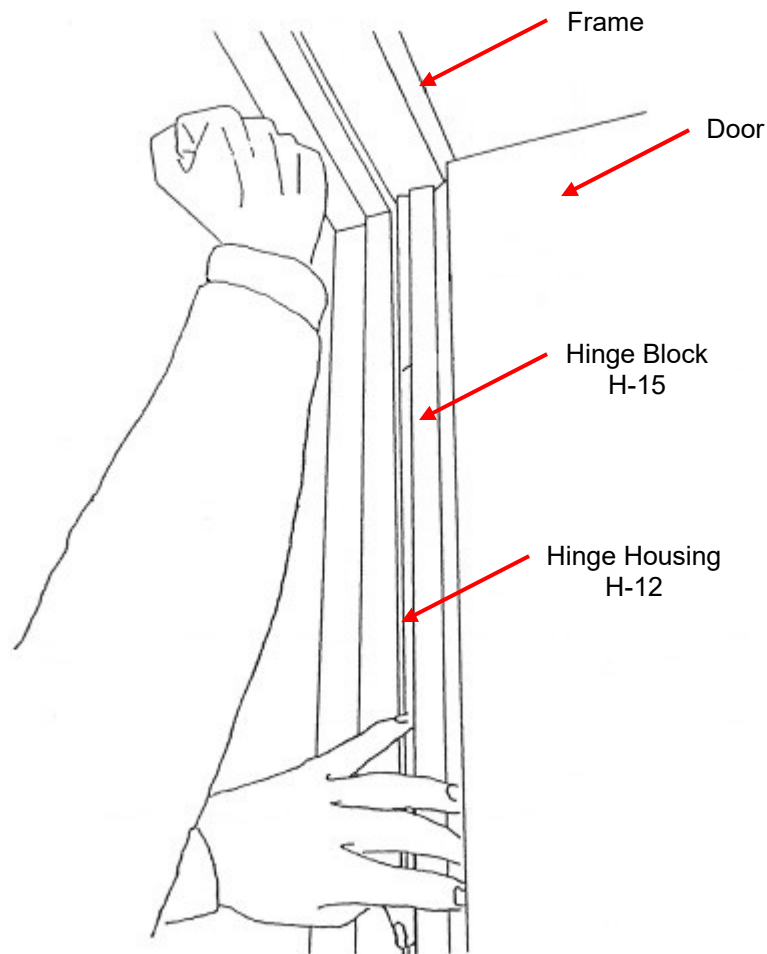



## One Piece Latch Stop, L55

**NOTE:** FAILURE TO FOLLOW THESE INSTRUCTIONS WILL RESULT IN DOORS NOT LATCHING, NOT LOCKING, OR BEING DIFFICULT TO OPEN OR CLOSE.

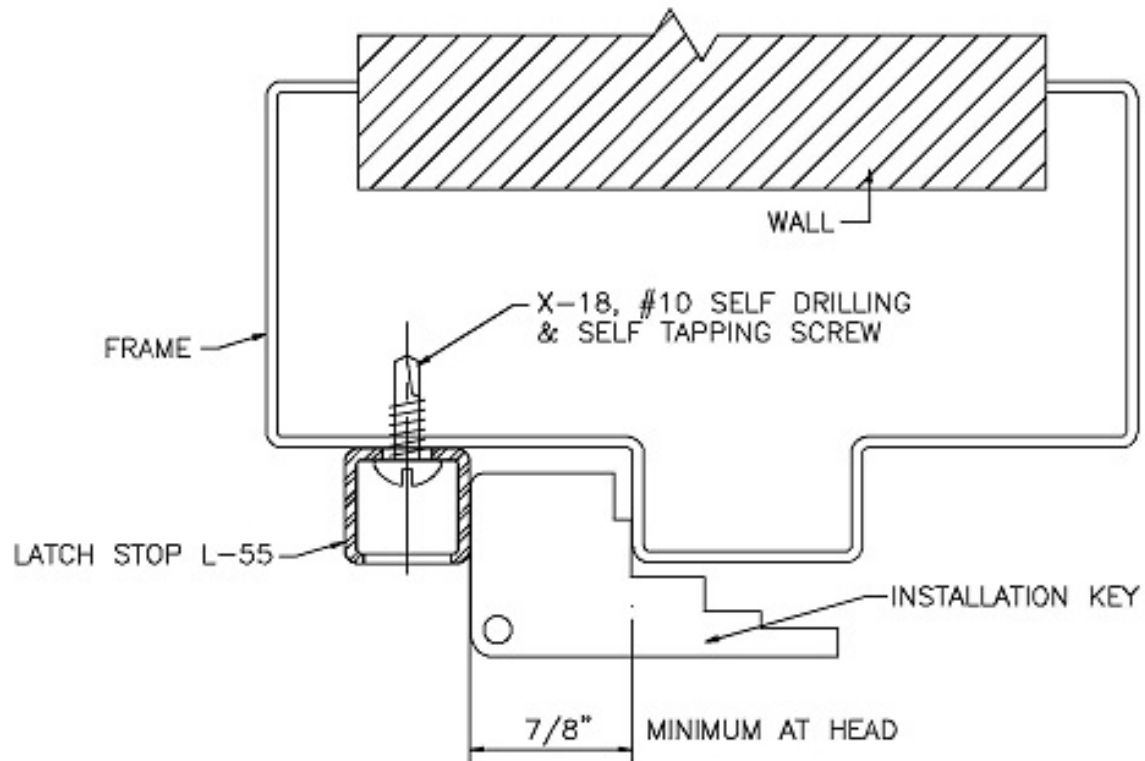

### LATCH STOP, L55, INSTALLATION PROCEDURE

1. Install top screw of latch stop, L55, with back side 7/8" from the frame stop. Use the installation key provided to insure correct tolerances.
2. Depress the retainer on the top of the door and straighten the locking channel, L11, to the locked position. Close the door firmly against the latch stop, L55. Press the L55 against the locking channel, L11, and scribe a line on the jamb the length of the L55 on the rabbet side.
3. With the L55 on the scribed line, install the bottom and middle screws.
4. Test the door for proper operation. If the door operates smoothly and easily, install the balance of the screws and the nylon hole plugs.

## Pairs of Doors Installation Instructions

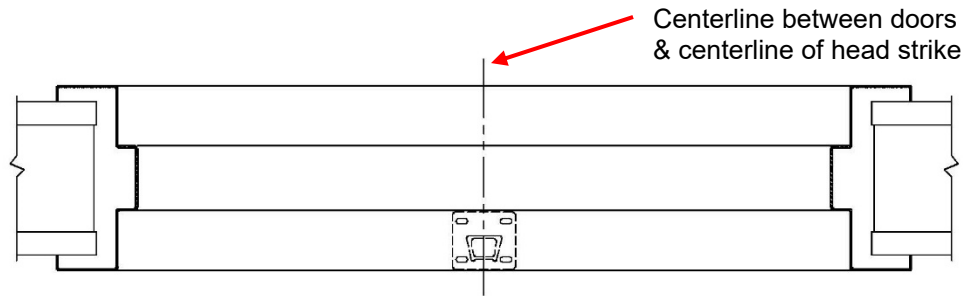

VIEW OF FRAME LOOKING UP AT HEAD

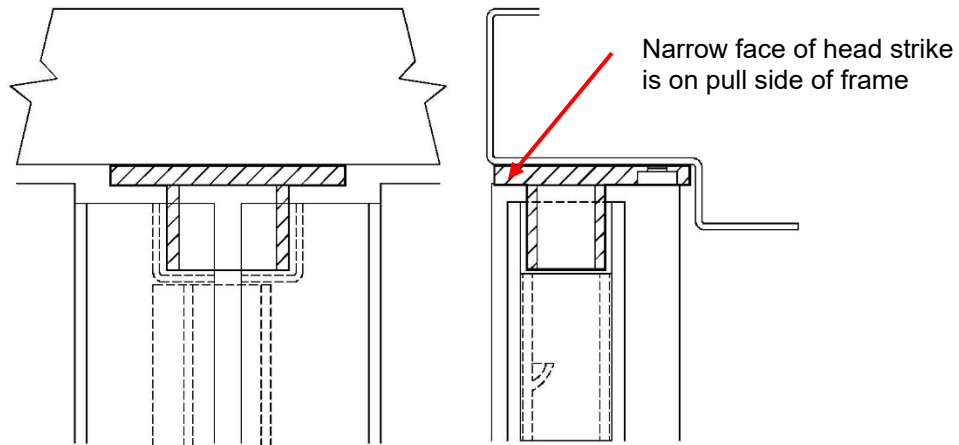

HEAD DETAIL AT LOCKING CHANNEL

### Installation Sequence

1. Check both frame legs for being plumb. If out of plumb  $1/8''$  or more, straighten jambs or mount hinge housings so that both are in the same plane.
2. Hang doors, mark centerline between doors and mount strike precisely in center of pair of doors, oriented as shown.
3. Latch doors against head strike; check to verify that doors are in line at bottom. If more than  $1/8''$  out of line, remount one or both hinge housings to correct misalignment.
4. Space between doors should be  $1/4'' \pm 1/8''$ . If other than  $1/4''$  space between locking channels, adjust tongue. If space is less than  $1/16''$ , adjust frame width or reorder doors to suit field condition. If space is over  $3/8''$ , put shims under one or both hinge housings to obtain  $1/4''$  space.
5. Adjust tongue so that it engages the mating locking channel by  $1/8''$  ( $\pm 1/16''$ ).
6. Use installation key, which is provided, to insure proper tolerances.

## Double Egress Doors Installation Instructions

Doors for double egress frames are automatically supplied oversize so that standard width frames may be used. Thus, double egress frames and doors are ordered 6070 or 5070 etc. Each leaf of a pair of doors for a 6070 double egress opening are supplied 3'0-7/16" x 7'0" in order to provide for a 1/4" overlap of the locking channels. The minimum overlap must be 1/8" in order to maintain fire rating.

1. Mount double egress doors in plain cased opening with applied head stops.

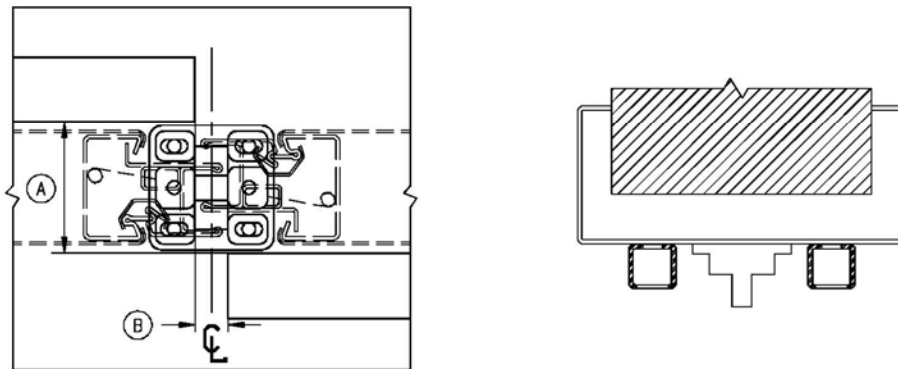
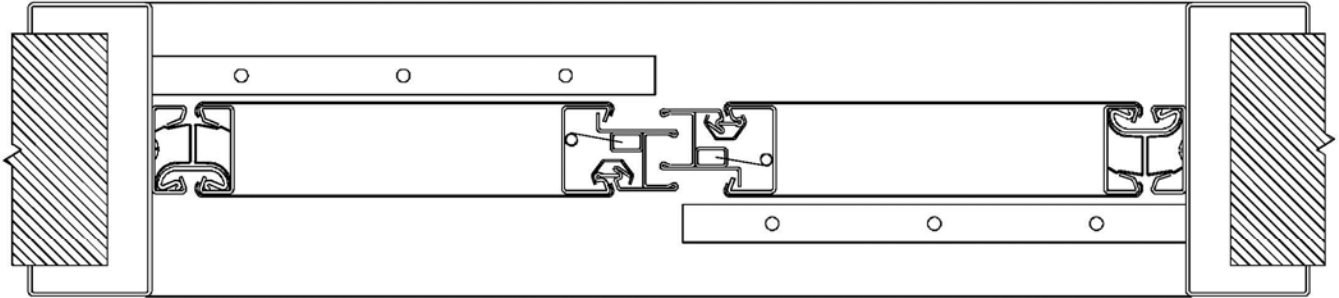

2. Distance between head stops (dimension A) must be 2".
3. Dimension (B) must always be 1/2" minus zero.

## Removable Mullion Installation Instructions

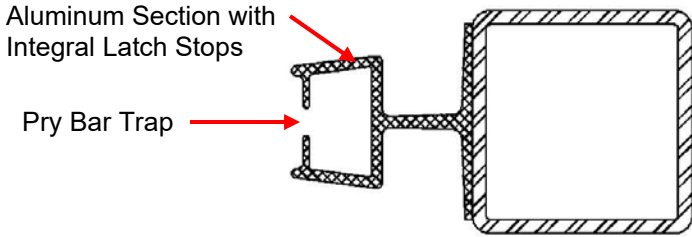

**Removable Mullion – L-38SA**

- Place open side of L-39, 1/8" back from the edge of stop on soffit at the exact centerline of the locking channels. Attach L-39 using one screw in slot.

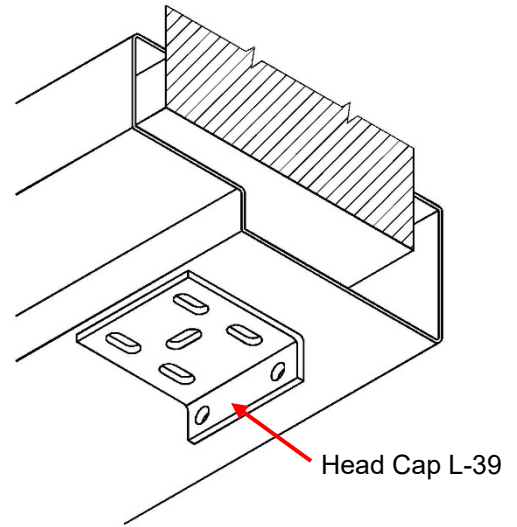

- Plumb from above and attach sill base L-40 to the floor at exact centerline of locking channels using appropriate screws.

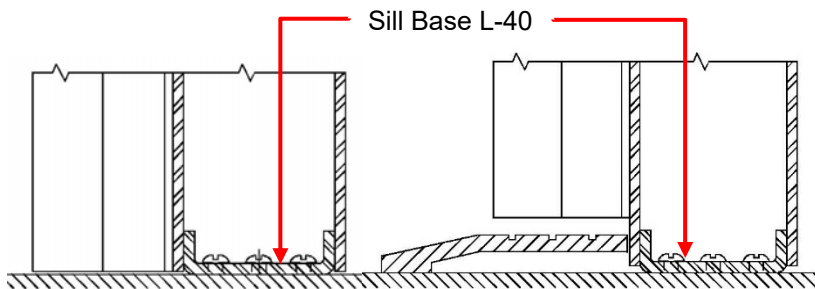

**A.** If floor is concrete or tile, install L-40.

**B.** If threshold is used, it must be notched to allow the L-40 to be installed directly on the floor. The aluminum latch stop section must be notched as well to sit on top of threshold.

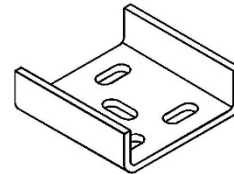

- Measure distance from underside of soffit to the floor (measurement X). Cut bottom end of the center mullion.

**IMPORTANT! The mullion must always be cut at the bottom.**

- Place the bottom end of mullion over the sill base L-40. Be sure mullion is forced down to the floor. Swing the top end of mullion into the head cap L-39. Be sure mullion is forced tightly against stop in head cap L-39 and check fit.
- Holding the mullion against the stop in head cap L-39, line up holes on the head cap and steel tube and install 1 screw at the back. Test operation of both doors simultaneously while holding the mullion in position. If mullion is in correct location, remove mullion and install remaining screws on the head cap L-39.
- Set the mullion back in place and insert the two set screws at the back of the head cap L-39 and tighten securely.

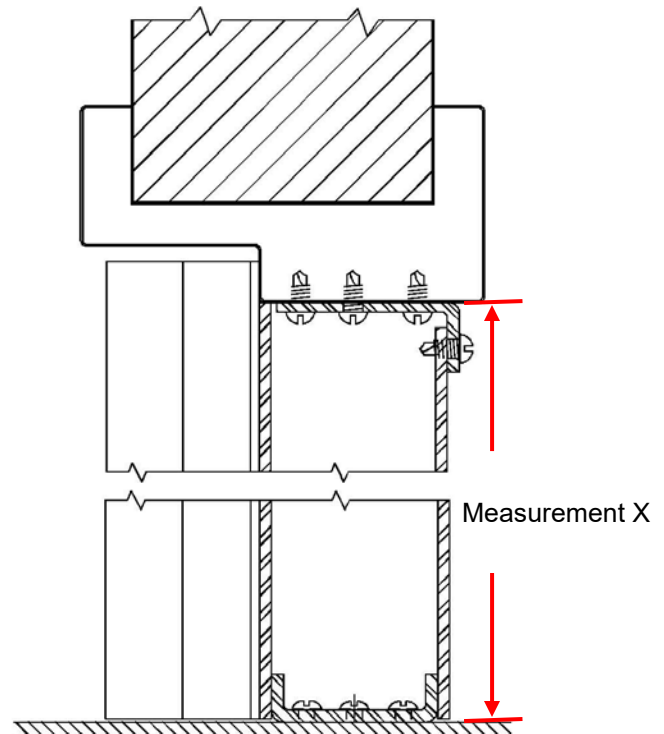

## Installation of Levers on Panic Doors

1. Remove hinge end cap on panic and slide panic bar 6" toward hinge side of door. Refer to Tech Data Sheet 1F.
2. Seat lever into escutcheon.
3. Insert Phillips Head screwdriver through plug Q-30 and tighten screw to the lever spindle. Screw must be set tightly to avoid loosening.
4. Slide panic bar into position and check operations. Reinstall end cap.

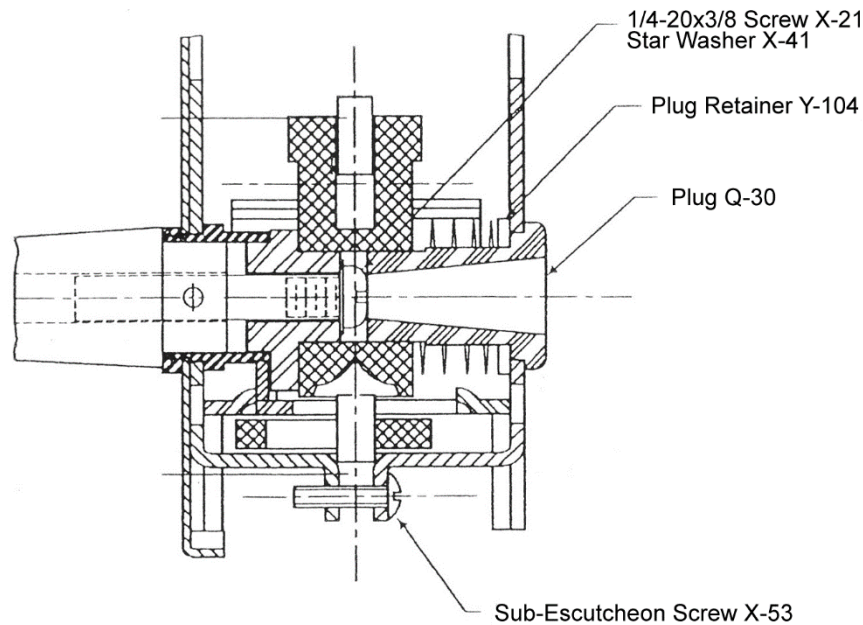

## Cylinder Installation

Customers cylinders may be factory or field installed. Any mortise cylinder (not longer than 1-3/8" nor shorter than 1-1/8" with standard cam) may be used. See Tech Data Sheet #25-05.

1. Remove the hinge side panic end plate and slide the panic bar back to access the mechanism. Hold hand over panic as you slide bar back to catch the panic button, which will pop out.
2. Loosen top screw in the mechanism housing, approximately six (6) turns and then loosen the bottom screw approximately one and one half (1-1/2) turns.
3. Tilt the top of the pull side lever mechanism outwards so that the cylinder setscrews on the side of the mechanism can be loosened.
4. Screw cylinder into lever mechanism. Make certain that cam leg points toward top of mechanism when key is removed. Tighten setscrews firmly against cylinder.
5. Re-tighten top and bottom screws in mechanism.
6. Slide panic bar back into position after replacing the panic button assembly and replace the hinge side panic end plate.

## Lever Handle and/or Cylinder Installation

The lock mechanism with escutcheons is installed at the factory. The lever handles are shipped in a separate container with the door.

### Levers Installation

1. Install the outer lever complete with swivel spindle. Make certain that the swivel spindle is adjusted so that the distance from the nylon plug to the face of the escutcheon nut is  $5/32"$ . The nylon plug must be horizontally positioned to receive the lever setscrew.
2. Install the inner lever and tighten the setscrew firmly. The setscrew **must seat into the nylon plug**.
3. Test operation of levers.

### Cylinder Installation

Customers cylinders may be factory or field installed. Any mortise cylinder (not longer than  $1-3/8"$  nor shorter than  $1-1/8"$  with standard cam) may be used. See Tech Data Sheet #25-05.

1. Loosen setscrew and remove inside lever. Then remove outside lever.
2. Remove escutcheon nut from escutcheon plate on the non-secured side with the tool provided and remove the escutcheon plate.
3. Loosen top screw in the mechanism housing, approximately six (6) turns and then loosen the bottom screw approximately one and one half ( $1-1/2$ ) turns.
4. Tilt the top of the pull side lever mechanism outwards so that the cylinder setscrews on the side of the mechanism can be loosened.
5. Screw cylinder into lever mechanism. Make certain that cam leg points toward top of mechanism when key is removed. Tighten setscrews firmly against cylinder.
6. Re-tighten top and bottom screws in mechanism and install escutcheon plate and levers.

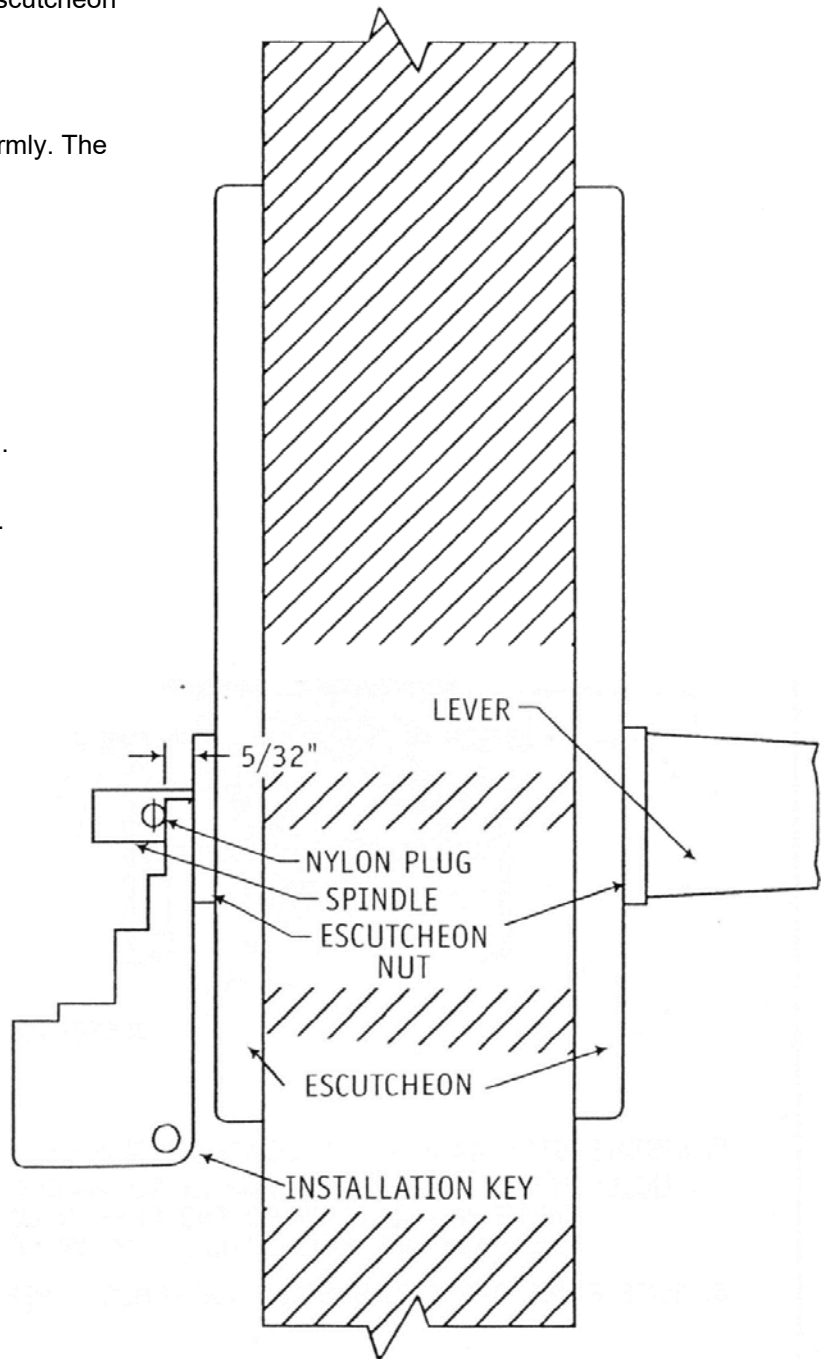

# Lock Replacement

1. Remove existing lock.
  - A. Loosen set screw on Lever. Remove both handles.
  - B. Use spanner wrench to remove escutcheon nuts. Remove both escutcheons.
  - C. Remove the two screws located at the top and the bottom of the lock unit and remove lock.
  
2. Install new lock
  - A. Remove top and bottom screws from the new lock mechanism. Separate the two halves of the lock carefully so that all parts stay in place.
  - B. With the locking channel in the open position, insert the half of the lock containing the actuator (Part# Q-17, see Parts section 1-3) on the pull side of the door. Make sure that the actuator grips the blocking member (Part# L-135SA, see Tech Data Sheet # 21) as it is installed. Once the first half of the lock is in place and the actuator is seated on the blocking member, install that second half of the lock. Once seated, secure the top and bottom screw.
  
3. Reinstall escutcheon plates and levers. Follow the instructions provided on the previous page.

## Push-Pull Grips (Factory Installed)

### Removal of Grips

**NOTE: The Push-Side grip must be removed first**

1. Open door and depress retainer R12 located at top of door on latch side (this action releases a tab holding locking channel L11 in the unlatched position) and rotate locking channel L11 to latched position (in plane with door body).
2. In base of locking channel, at grip height, locate the hole (approximately 1/8" in diameter) for access wire.
3. Take access wire tool Y39A and place long end into hole in locking channel. Feel for corresponding hole in door stile.

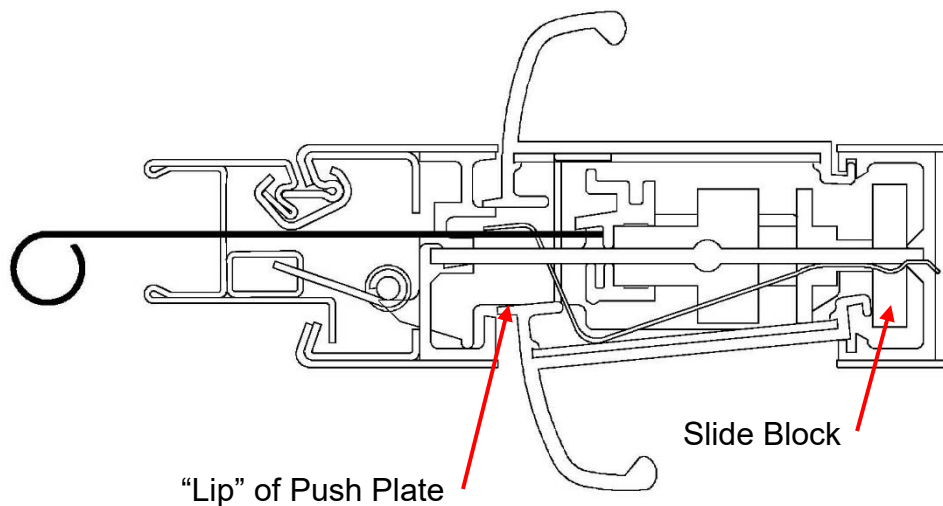

4. When wire through both holes, it meets the slide block member of the mechanism. Push access wire toward hinge side of door, pushing the slide block to rear of mechanism.
5. Grasp **Push-Side** grip in one hand while holding access wire fully depressed with other hand. Push the hinge side of the grip inward at the same time pulling the entire grip out of mechanism cutout.
6. The grip will come free on latch side. Pull grip out of door.
7. To remove **Pull-Side** grip, first return locking channel, L11, to the unlatched position. Use access wire to lift puller-rod free of actuator arm, M22.
8. Remove **Pull-Side** grip in same manner as Push-Side.



## Push-Pull Grips/Cylinders (May be Factory Installed)

When cylinders are not factory installed, Total Door Systems® provides one each knurled cylinder nut and one each blocking ring for each cylinder type grip.

### Preferred Installation

The push-pull grip is designed to work with all cylinders up to 1-3/8" long, without collars or blocking rings under the head.

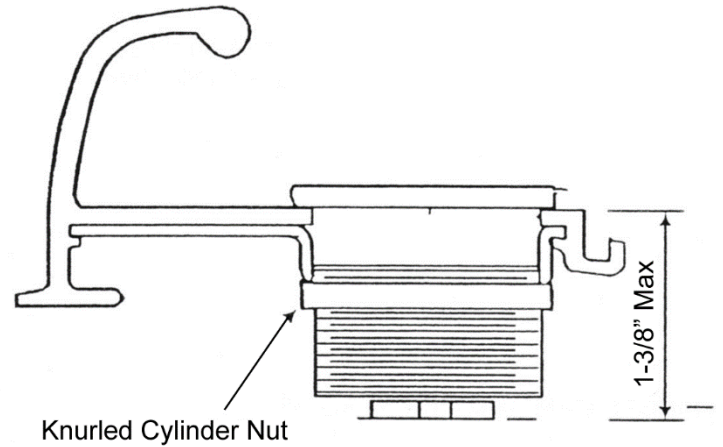

### Cylinder Installed with Blocking Ring Under Knurled Nut

If the cylinder is not sufficiently threaded, use blocking rings under the knurled cylinder locking nut.

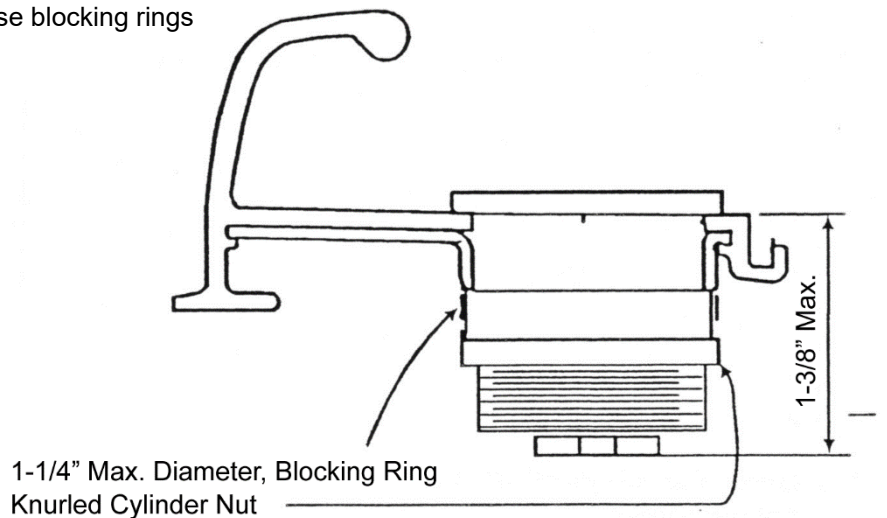

### Cylinder Installed with Blocking Ring Under Head

If the cylinder is more than 1-3/8" long, use blocking rings under the head. Never use cylinder collars on Total Door Systems® grips. Installation of the grips in the mechanism will be very difficult or impossible.

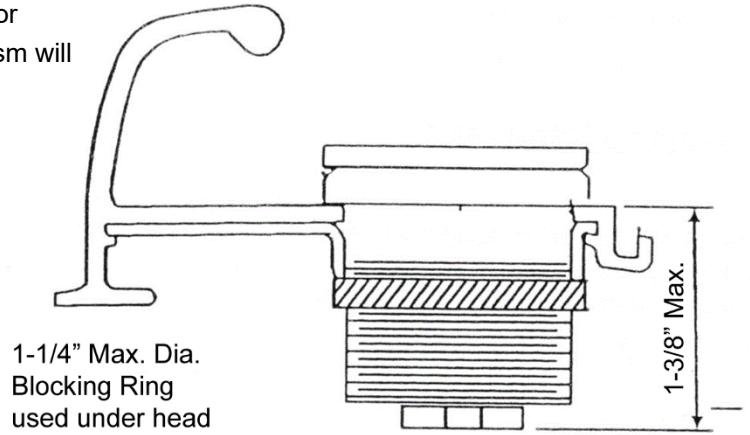

### Proper Cylinder Cam and Orientation

Cylinder cam must be Adams Rite cam.  
(See Tech Data #25-05)

Orientation: Cam of cylinder must be closest to center of mechanism.

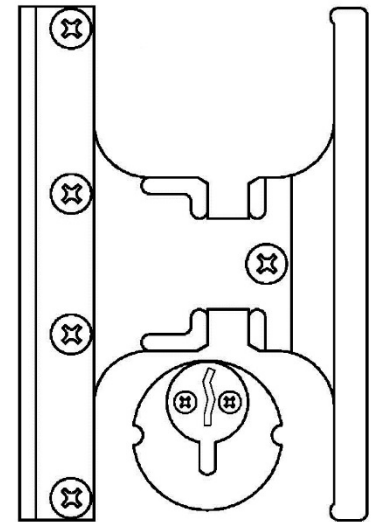
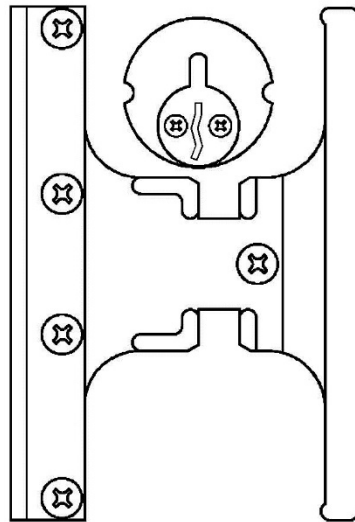

## Pull Plate

The Pull Plate is distinguished by having a Puller Rod, which attaches to the Actuator in the mechanism. The Pull Plate must be installed **before** the Push Plate.

1. Place the Pull Plate in the mechanism as shown.

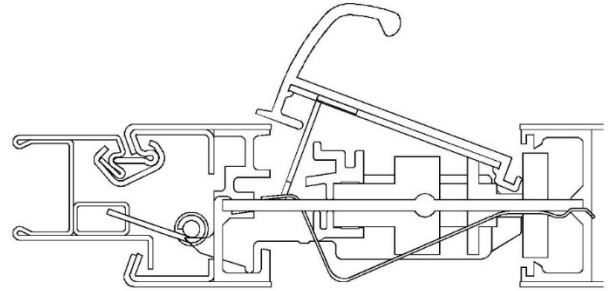

2. Push the Pull Plate against the Slide Block and slide both toward the hinge side of the door (in direction of the arrow) until further motion is impossible. Using the access wire provided, reach through the mechanism from the Push Side and pull the Puller Rod over the Actuator.

**NOTE:** During this operation, the Pull Plate must be held in the “pushed in” position.

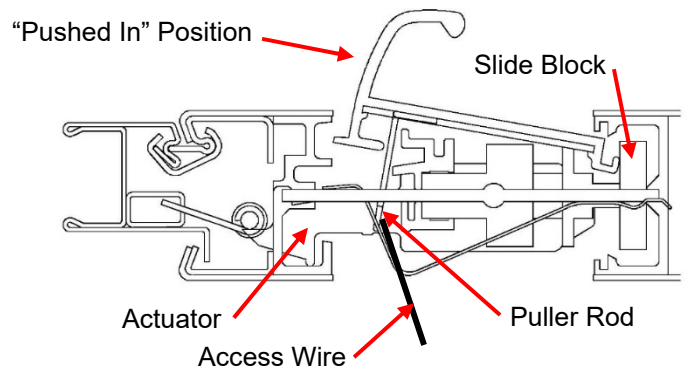

3. Push the Actuator, allowing the Puller Rod to snap over the Actuator. Remove the hooked wire.

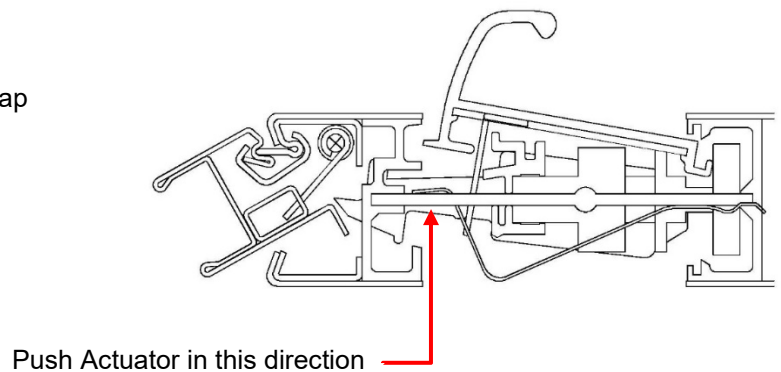

4. Return Actuator to position shown. Keeping the Slide Block in the full “pushed in” position from the push side, seat the Pull Plate in the pivot groove. Holding the Pull Plate in the seated position, allow the Slide Block to return, thereby capturing the Pull Plate in the pivot position.

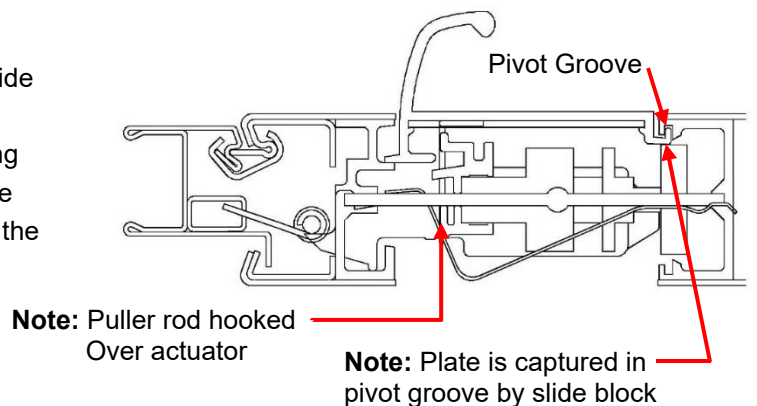

- Install the two Plate Springs in the mechanism. Hook the leg of the spring that is closest to the center of the mechanism under the lip of the Pull Plate. Hook the other spring (for Push Plate) over the Pull Plate side of the mechanism web. Test the operation of the Pull Plate by opening and closing. Check cylinder or turn piece operation, if applicable.

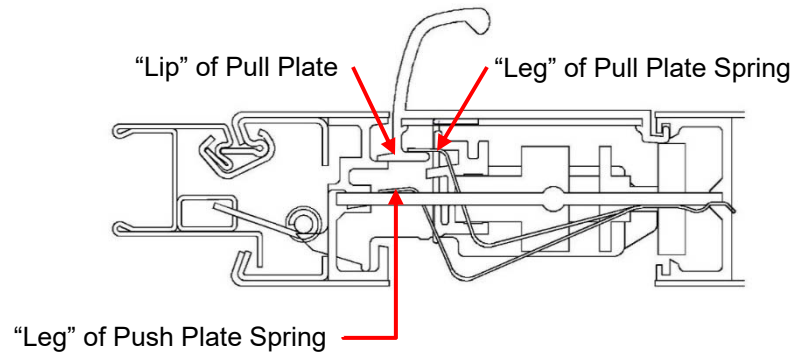

- Place Push Plate in mechanism as shown.

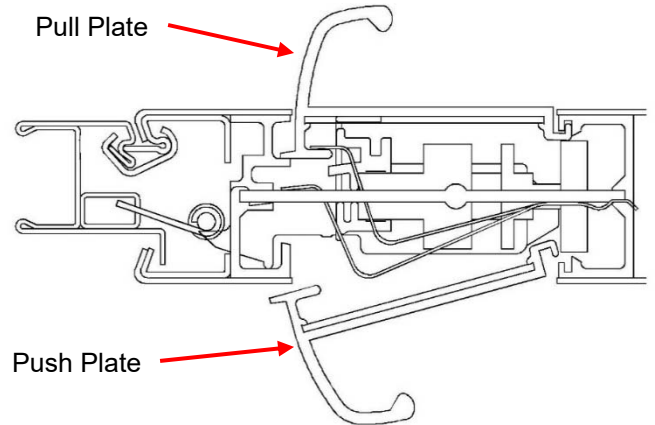

- Slide Push Plate from hinge side and seat Push Plate in pivot groove.

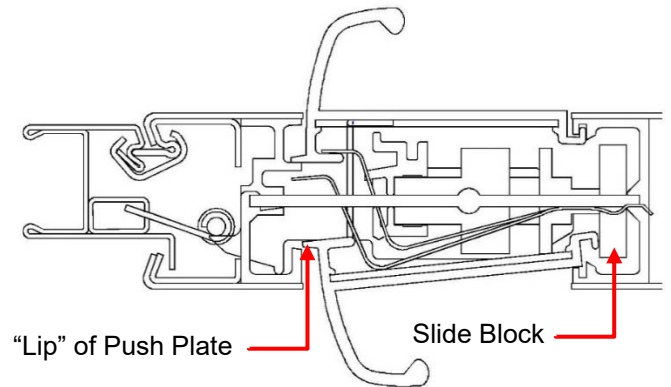

- Wiggle both Pull and Push Plates until Slide Block returns, capturing both plates.

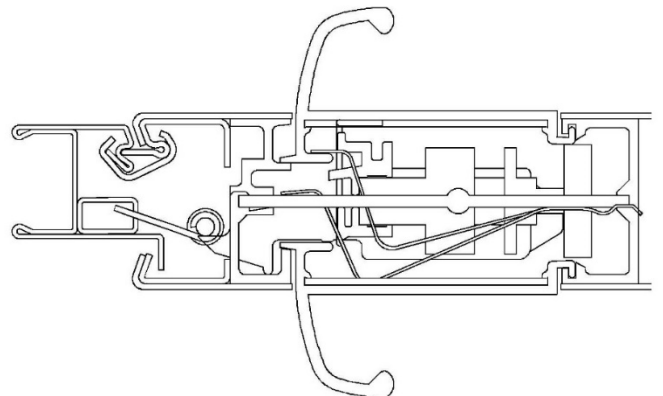

# Troubleshooting

Latch Side	3-1
Hinge Side	3-3
Hanger Rod	3-4
Grips	3-5
Key Cylinder	3-7

## Latch Side Problems

1. Door will not latch.
  - a. Distance from back of Latching Stop to rabbet is less than 7/8" or latch stop is out of line with the door.

Latch Base to Frame Stop  
Use 7/8" portion of "KEY" to check for minimum distance

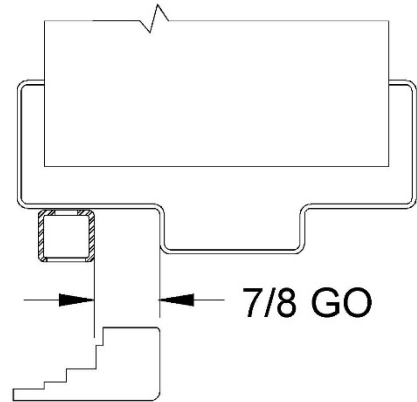

- b. Locking channel touching or appearing to almost touch the frame.

**NOTE:** Minimum clearance of 3/32" between frame and locking channel.

Locking Channel to Frame  
Use thickness of "KEY" (3/32") to check for minimum clearance.

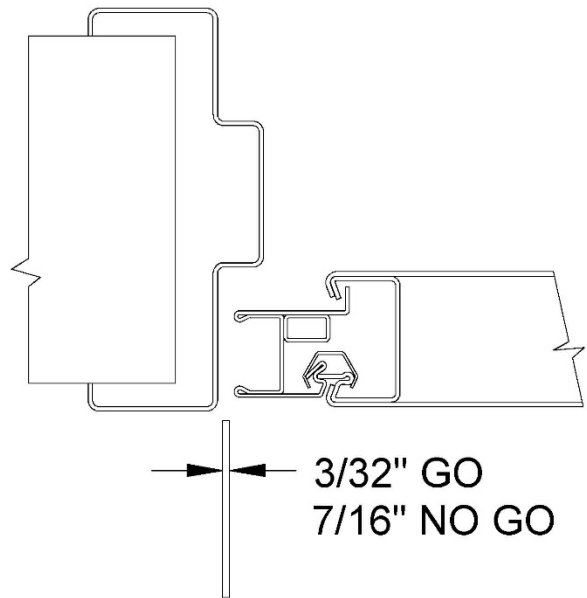

- c. Kickplate is too wide and mounting screws too long. Due to width of locking channel and hinge members, kickplates should be ordered 4" narrower than nominal opening dimension.

**NOTE:** This does not apply to kickplates provided and factory installed by Total Door Systems®.

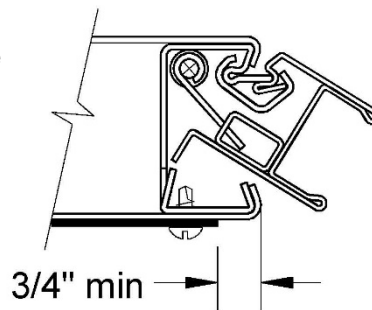

Kick Plate  
Minimum distance from edge of kickplate to edge of door skin = 3/4"

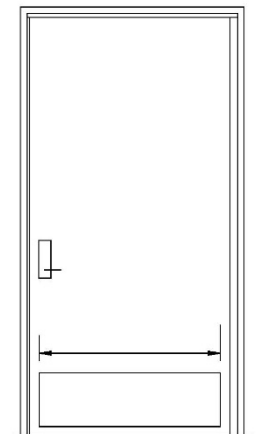

Kickplate width equals nominal frame size less 4"

**Avoid the problems entirely by using Total Door Systems® kickplates, factory installed.**

- d. Installer has substituted mounting screws when installing panic. Screws over 1/2" long will affect actuator or lip of locking channel. *Interference Similar to #3*
  
- e. Excess head clearance between door and frame. Retainer cannot disengage from locking channel. Head clearance must be less than 1/4"

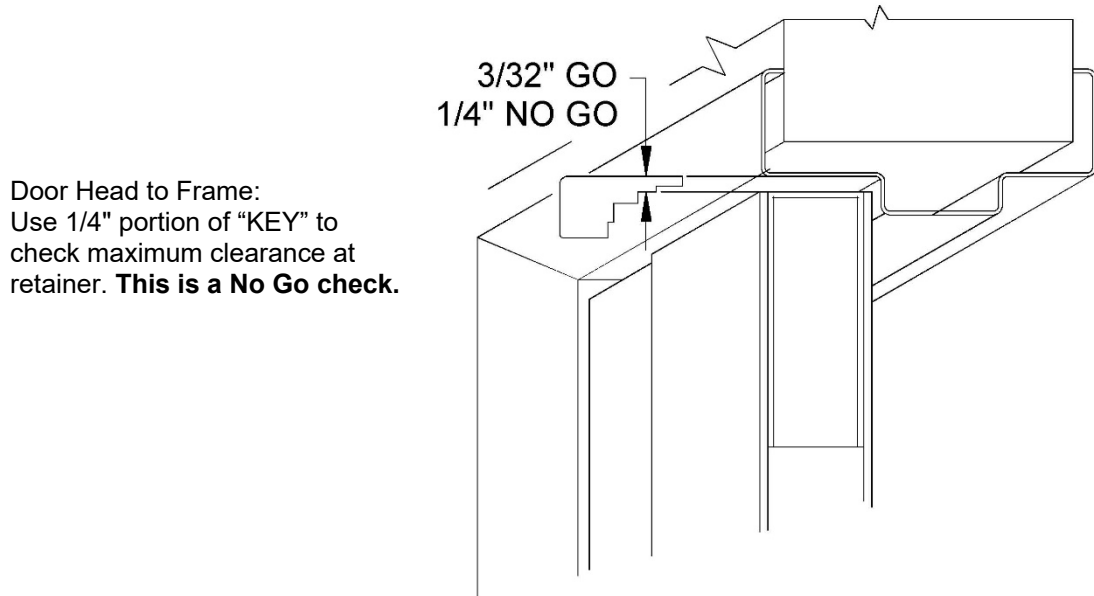

- f. Actuator out of synchronization with blocking member. Occurs occasionally during shipping of grip style doors. To correct, hold locking channel in latched attitude while operating push grip.

**Avoid All Latch Stop Problems by Always Using the Total Door Systems® Latch Stop**

## Hinge Side Problems

1. Difficult to engage hinge into hinge housing, H-12. Problem – Jamb of frame badly bowed.
  - a. Shim H-12 until straight.
2. Hinge block, H-15, difficult to install/hinge not fully seated.

**NOTE:** Start insertion of H-15 only at top of door or frame.  
Pivot hinge to maximum angle

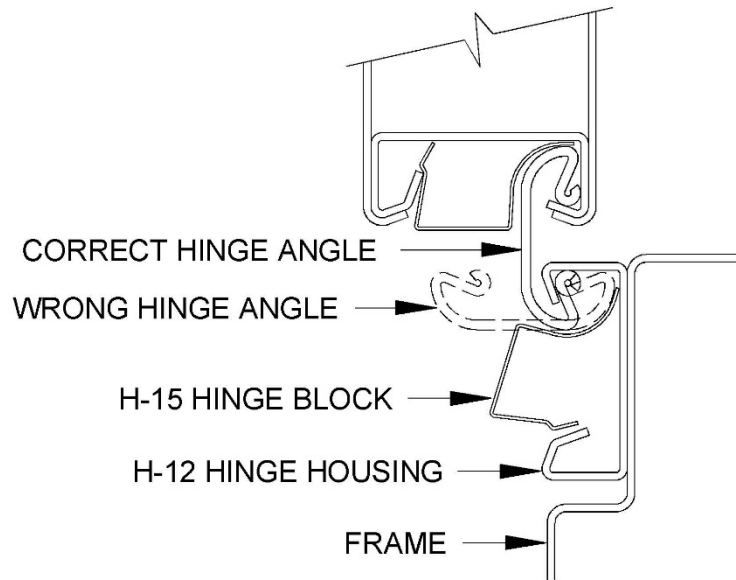

3. Door hangs too low.

Raise hinge housing to achieve proper tolerance at the retainer.  
(See TDS 36-02)

4. Door too high – won't close.  
Reverse of 3 above:

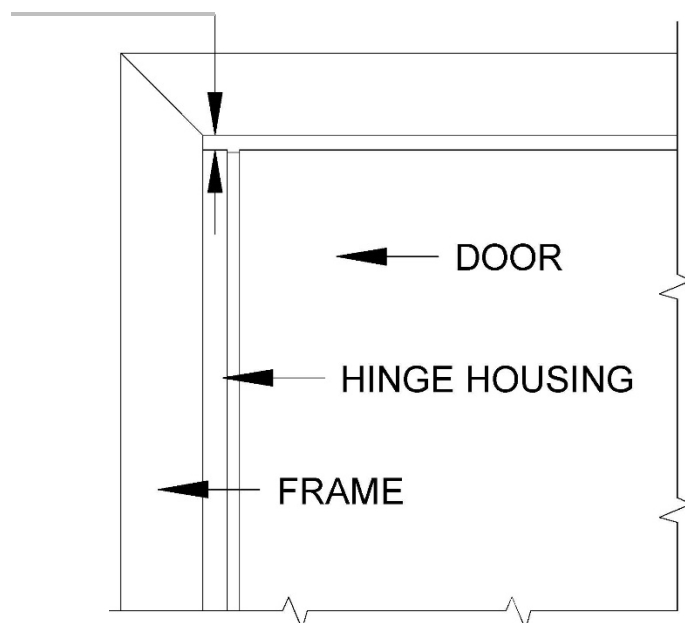



## Hinge Side Problems (continued)

5. Hinge Housing Pulling Away From Frame:
  - a. Install all 15 screws supplied. In hinge housing, H-12, there must be at least 6 screws installed at top.
  - b. If door has been abused and frame is puckered at screw locations, back screws out 3 turns and rap smartly with hammer to form dimple. Retighten screws.
  - c. Do not use explosive fasteners to anchor hinge housing to a fully grouted frame – impact causes concrete to pucker at fastener about 1/16".

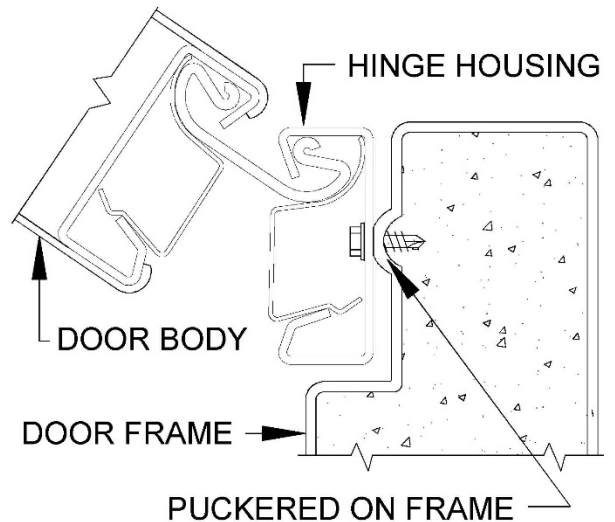

## 6. Hanger Rod Failure

*Our experience indicates that there are 3 reasons that hanger rods break.*

- a. The frame head is sloped down at the latch side and the action of closing the door forces the door downward – thus over-stressing the hanger rod.

**SOLUTION:** Lower the hinge housing so that there is a 1/16" clearance between the door and frame head at the latch side.

- b. The frame hinge jamb is bowed more than 3/16". This puts a bind on the hinge, creating heavy bearing loads. The hanger rod, as it twists during door cycling, becomes shorter, then longer as it straightens out. This means that the door must be free to pump up and down as it opens and closes OR it will be over-stressed because its length is restrained due to the bowed hinge jamb.

**SOLUTION:** Shim the hinge housing so that it is brought to straight + 1/8". Please note, a 1/4" bow in the frame CANNOT be discerned by looking. Please use a minimum 6-foot straight edge.

- c. Improper procedure during installation (see Tech Data Sheet #40). When the door is hung, if the top is pulled away from the jamb by more than 6", the hanger rod hook will open up, and cause stresses that can lead to failure.

**SOLUTION:** When hanging or demounting the doors, unhook the hanger rod before pulling the hinge stile more than 6" from the frame.

## Grip Problems

### 1. Groups Won't Go Into Mechanism

- a. Do not use cylinder collar. Use blocking ring *smaller* than cylinder head only if cylinder is over 1-3/8".

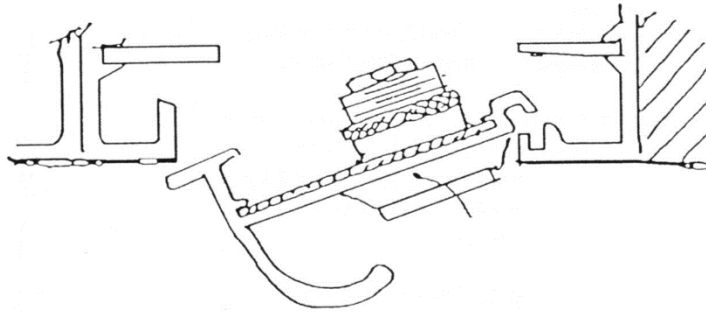

Cylinder Collar  
DO NOT USE

- b. Back plate misaligned – center by tapping at top or bottom.

- c. Back plate deformed out or in top and bottom of back plate must be 90 degrees to grip.

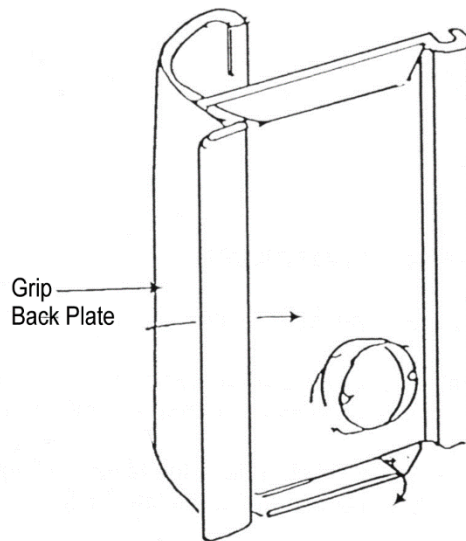

- d. Improper technique on clearing puller rod on pull grip. See *Installation Instructions*.

- e. Grip being installed at too great an angle; use lowest angle possible, especially when using long cylinders.

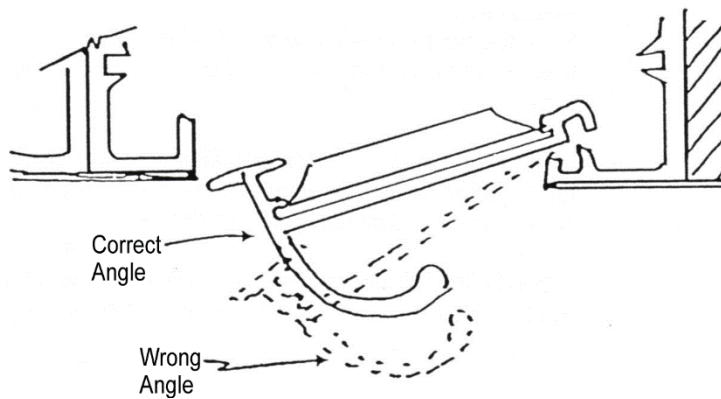

## Grip Problems (continued)

### 2. Grips Won't Seat

- a. Check pivot edge of grip for bends or nicks – especially if dropped on a hard floor.

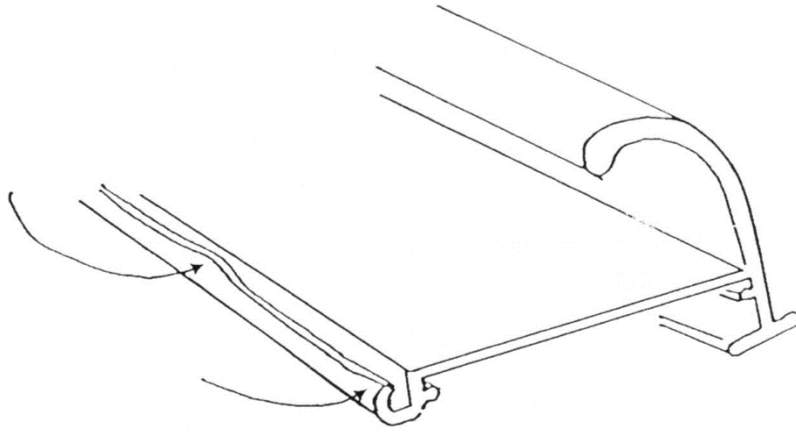

- b. Try seating both grips simultaneously – use both hands.

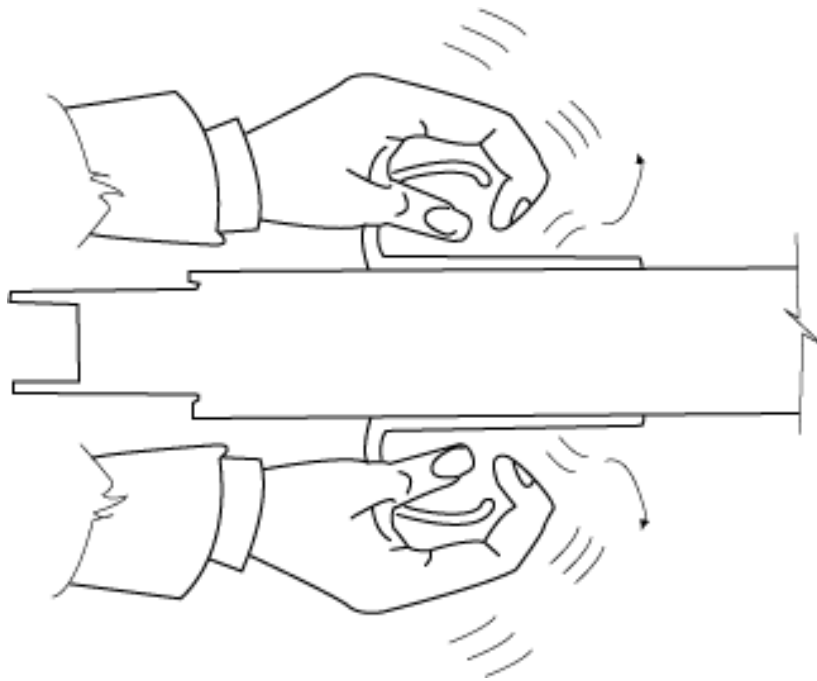

### Grip Problems (continued)

#### 3. Key Cylinder Doesn't Operate Properly

- a. On removable core Best cylinders, one or both cam rivets are loose or missing.



- b. Cylinder not properly keyed – key “drags”

- c. Cylinder installed with wrong orientation by 180 degrees. Correct cam orientation shown.

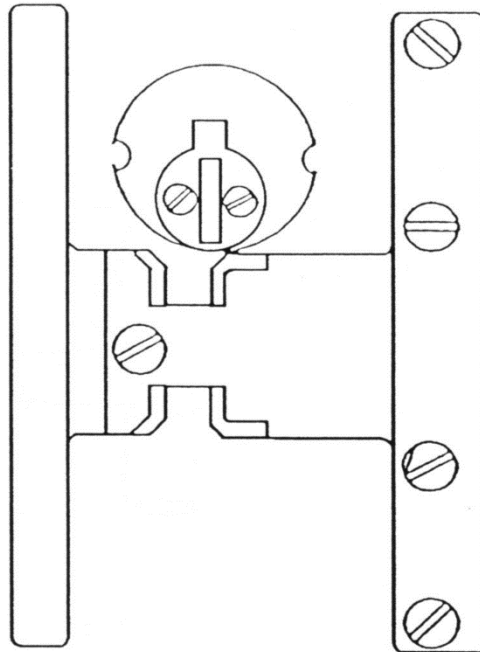

- d. Wrong side of door locks – wrong grips used. Puller rod is installed on wrong grip. Remove grips and change puller rod to proper grip.

- e. Cam wrong length – too long or too short – use Adams Rite cam designed for Adams Rite #MS 1850A dead bolt lock (the one with the long pivoting dead bolt).  
(See Tech Data Sheet #25)

# Technical Data Sheets

## **Exit Devices**

- Flush Panic Bar and Trim Removing
- Flush Panic Bar Dimensions
- Standard Panic Assembly
- Field Door Preparation for Standard Panic

## **Weather Seal**

- Weather Seal for Pairs
- Weather Seal for Single Doors
- Pair Head Strike Weather Seal

## **Hinge Side Components**

- H-17 Hanger Rod Installation
- H-50 Hanger Rod Installation
- Hinge Part Parts and Numbers
- Pivot Point of Hinge
- Rigidized Hinge

## **Installation**

- Installation Key

## **Latch Side Components**

- Double Egress Pair Detail
- Double Egress Prep for 3 Step Frame
- Helper Spring
- Latch Side Parts and Numbers
- Latch Stop L-55
- Locking Channel Parts and Numbers
- Removable Mullion Detail
- Standards for Pairs

## **Mechanism**

- Cylinder Standards
- Escutcheon Installation
- Lever Designs
- Lever Spindle Fastening
- Push Pull Mechanism Parts and Numbers

# TECHNICAL DATA SHEET # 75

## FLUSH PANIC BAR & TRIM REMOVAL

### TO REMOVE FLUSH PANIC BAR

With the door in the open position, depress the retainer at the top of the door and rotate the locking channel into the latched position.

- 1) Remove the top screw from the end cap at the latch edge of the door.
- 2) Pull the panic bar out far enough so that the bottom screw clears the face of the door, then remove the second screw.
- 3) Pull the bar out until it clears the door face, lift the bar upward and remove it from the door body.

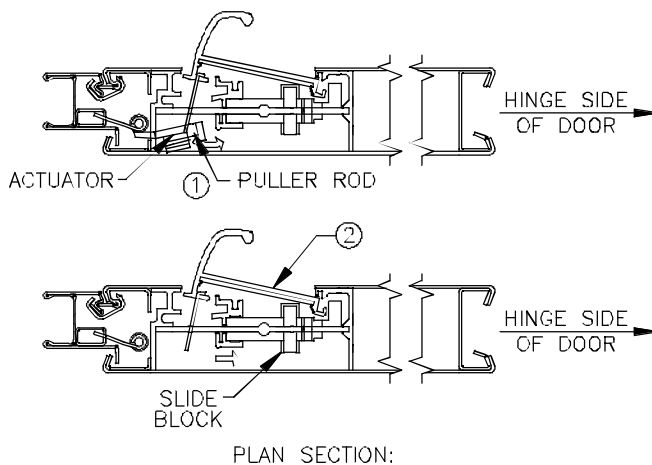
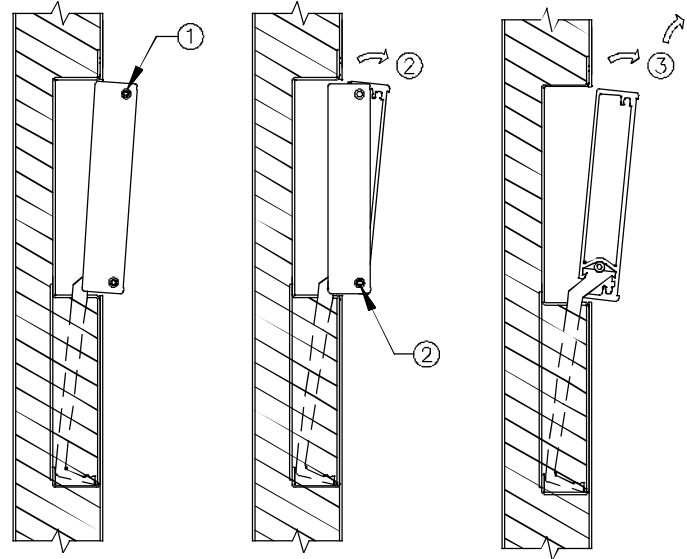

PLAN SECTION:

### TO REMOVE GRIP

- 1) Disengage the puller rod from the actuator by sliding it over the cap.
- 2) With one hand, push the slide block towards the hinge side of the door forcing the slide block to the rear of the mechanism. Grasp the grip with your other hand and push the hinge side of the grip inward at the same time forcing the entire grip towards the hinge side of the mechanism cut-out. The grip will come free from the latch side. Pull the grip out of the door.

### SECTION:

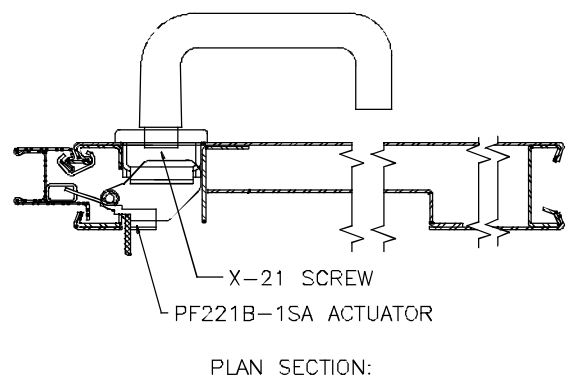

PLAN SECTION:

### TO REMOVE LEVER

Remove the phillips head anchor screw and slide lever out.

The installation procedure is the reverse of the above.

# TECHNICAL DATA SHEET # 72

## FLUSH PANIC BAR DIMENSIONS

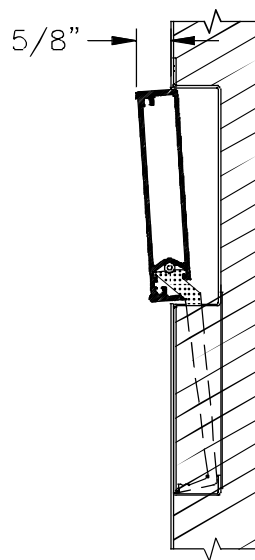
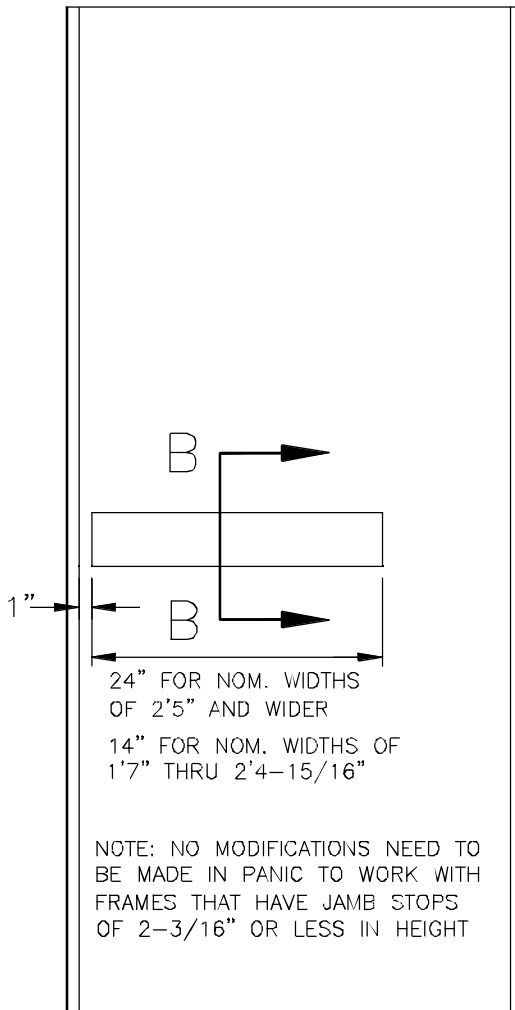

SECTION: B-B  
SCALE: 1:4  
DOOR IN CLOSED POSITION

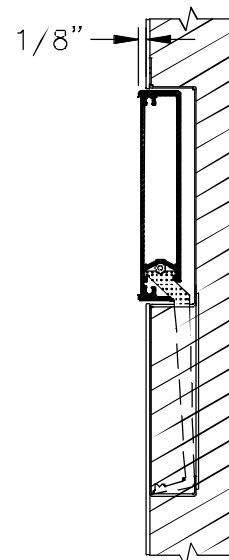

SECTION: B-B  
SCALE: 1:4  
DOOR IN OPEN POSITION

PUSH SIDE ELEVATION OF DOOR WITH FLUSH PANIC  
MIN. DOOR WIDTH NOM. = 1'7"  
MAX. DOOR WIDTH NOM. = 4'2-3/16"  
AVAILABLE IN POS. & NEG.  
PRESSURE LABELS THRU 3 HOUR



**Total Door** SYSTEMS™  
Global Leader in Integrated Access Technology™

TEL. (800) 852-6660  
www.totaldoor.com  
© Total Door 2013

FILE NAME
TDS72
DATE 8/30/13

# TECHNICAL DATA SHEET # 1 F

01

## STANDARD PANIC DEVICE - COMPONENT PART NAMES AND NUMBERS

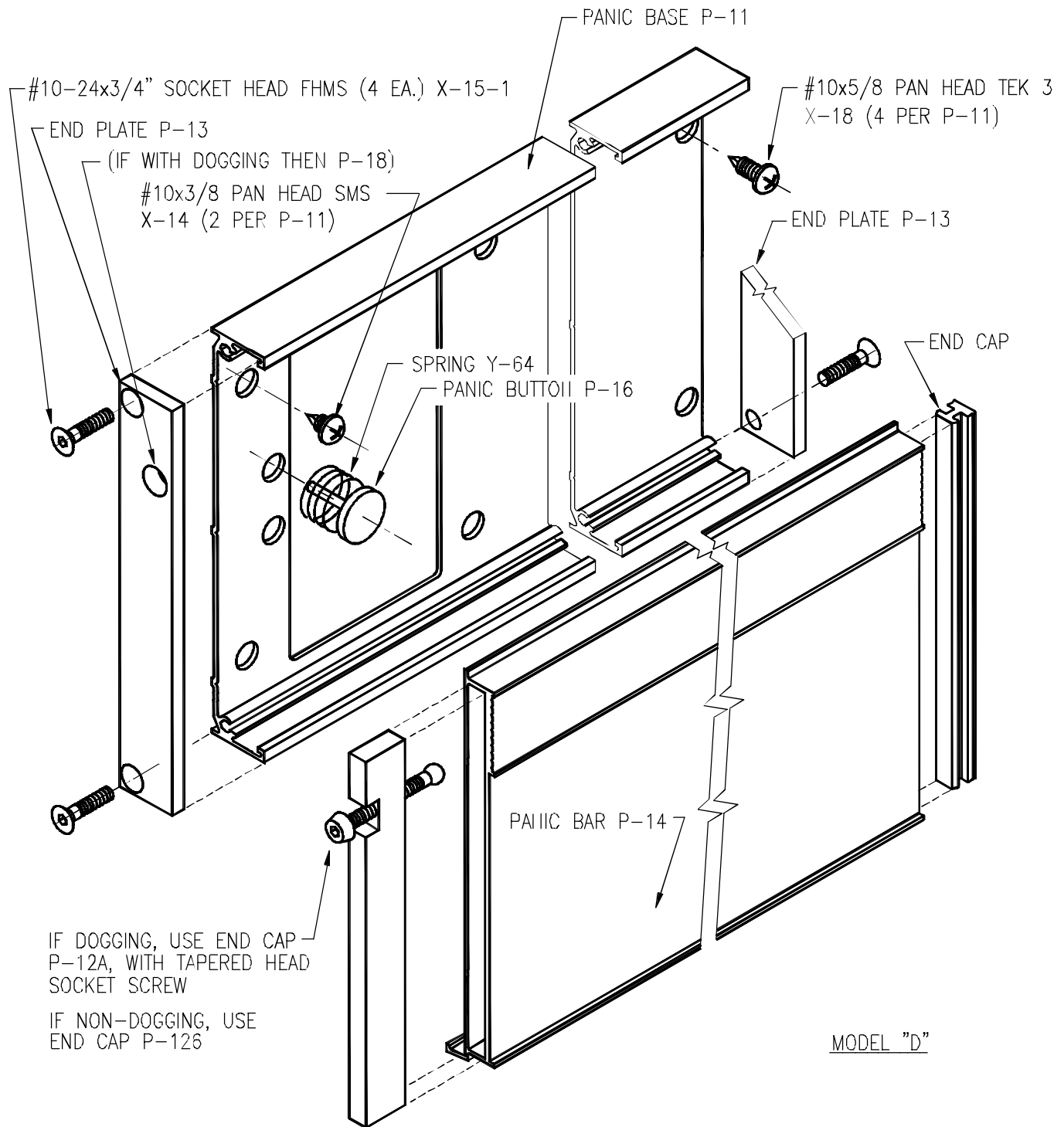

**Total Door** SYSTEMS™  
Global Leader in Integrated Access Technology™

TEL. (800) 852-6660  
www.totaldoor.com  
© Total Door 2013

FILE NAME
TDS1F-01
DATE 8/30/13



# TECHNICAL DATA SHEET # 27

01

## FIELD DOOR PREPARATION FOR STANDARD PANIC



SECTION VIEW

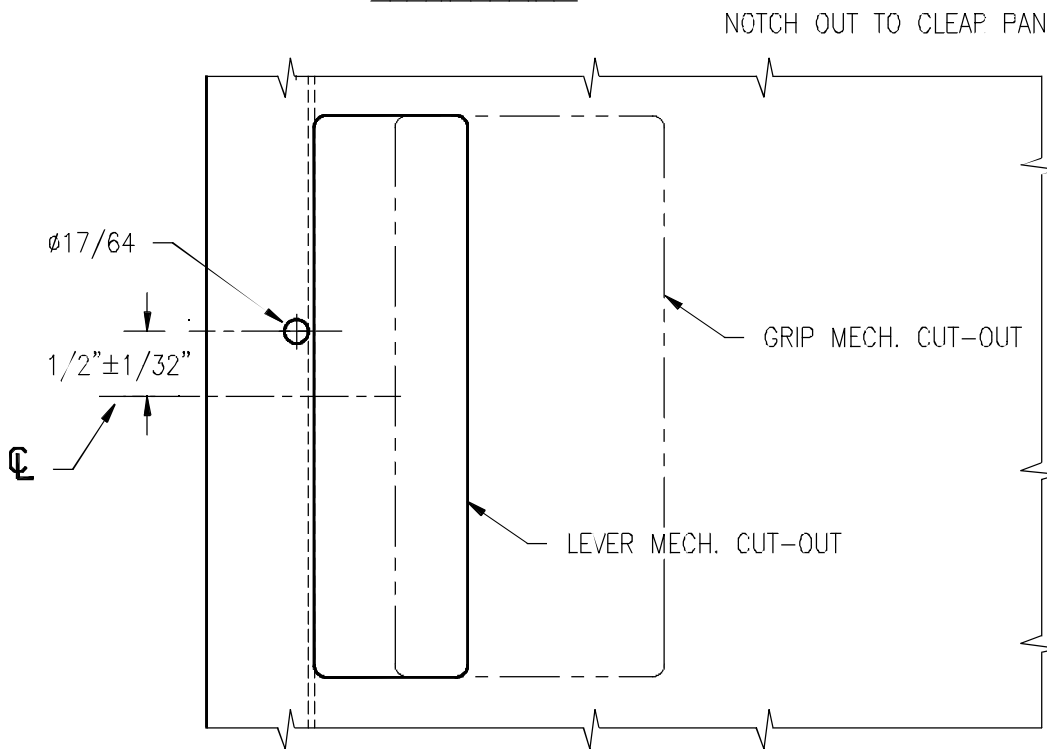

ELEVATION DOOR BODY - PUSH SIDE

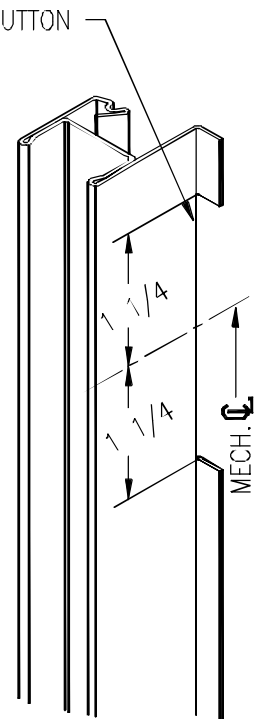

LOCKING CHANNEL MOD. FOR USE WITH PANIC.

DO NOT SCALE

NOTE: WHEN CHANGING TO PANIC FUNCTION IN FIELD, MECHANISM MUST BE CHANGED TO PANIC MECHANISM.

# TECHNICAL DATA SHEET # 4

01

## WEATHER SEAL – PAIR OF DOORS

**NOTE:** W-28A=1/2"x1/2"x2" CELLULAR FOAM. FIELD MOUNT ON FACE OF H-15, JAMB HINGE BLOCK, END OF W-28 TO TOUCH FRAME HEAD & SILL, (4 PIECES)

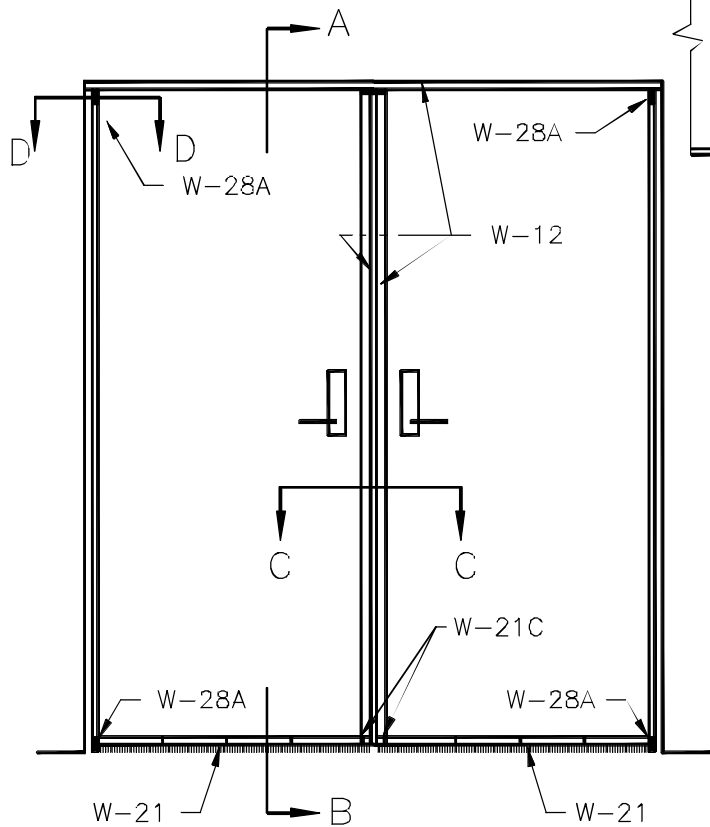

ELEVATION

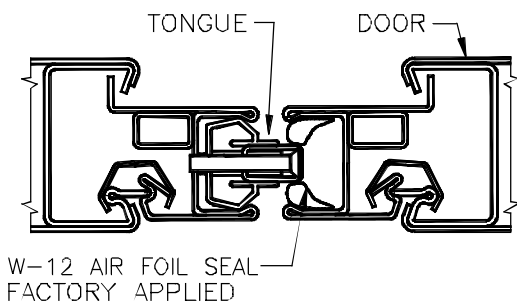

SECTION C

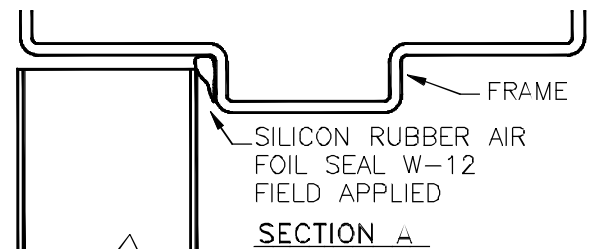
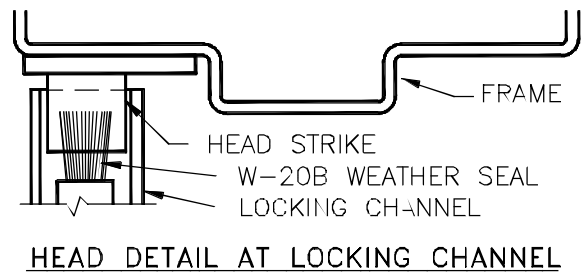
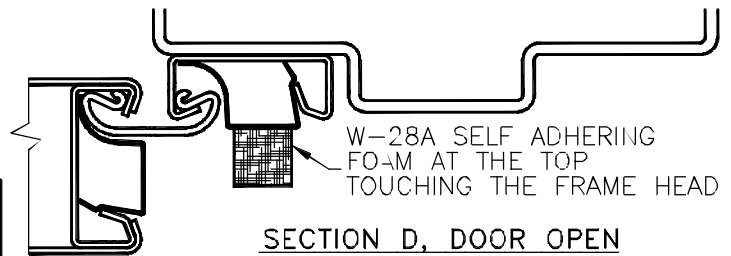

SECTION B

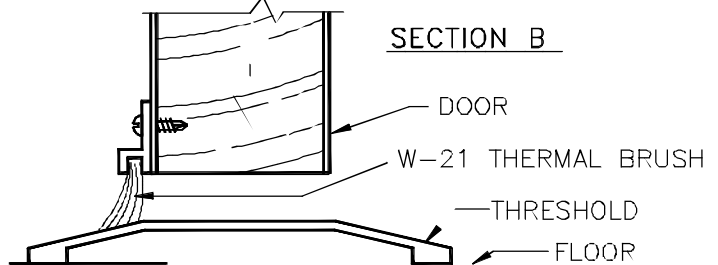

**Total Door** SYSTEMS™  
Global Leader in Integrated Access Technology™

TEL. (800) 852-6660

www.totaldoor.com

© Total Door 2017

FILE NAME

TDS4-01

DATE 5/4/17

# TECHNICAL DATA SHEET # 3

01

## WEATHER SEAL – SINGLE DOOR

**NOTE:** W-28A=1/2"x1/2"x2" CELLULAR FOAM. FIELD MOUNT ON FACE OF H-15, JAMB HINGE BLOCK, END OF W-28 TO TOUCH FRAME HEAD & SILL, (2 PIECES)

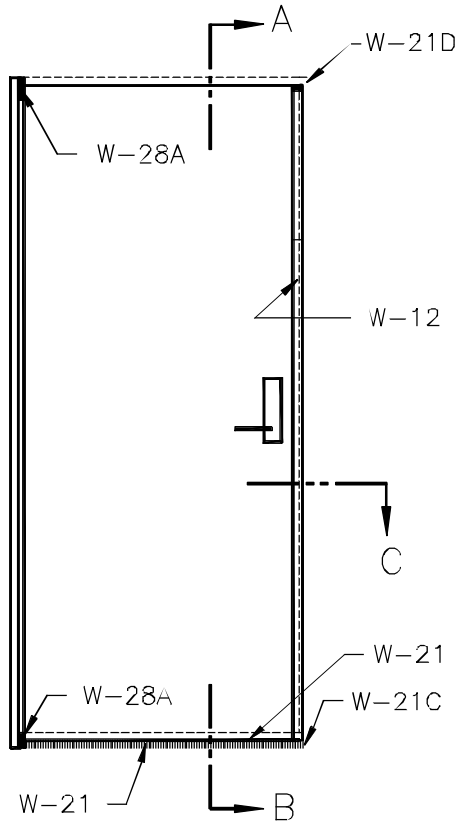

ELEVATION

LATCH STOP L-55  
W-12 AIR FOIL SEAL  
FACTORY APPLIED

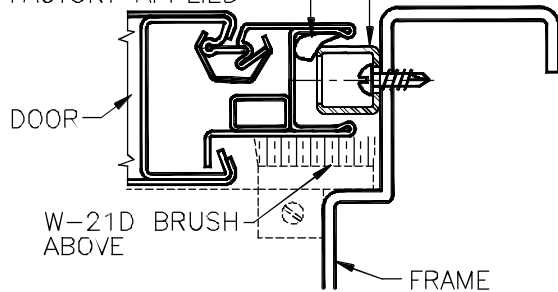

SECTION C

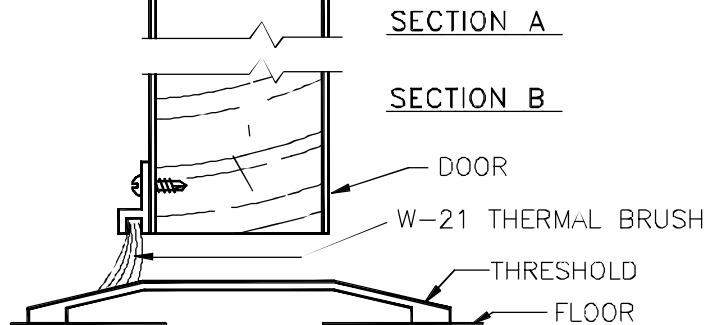
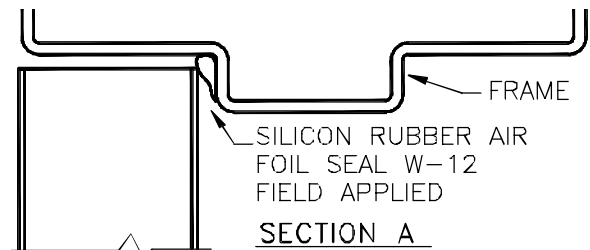
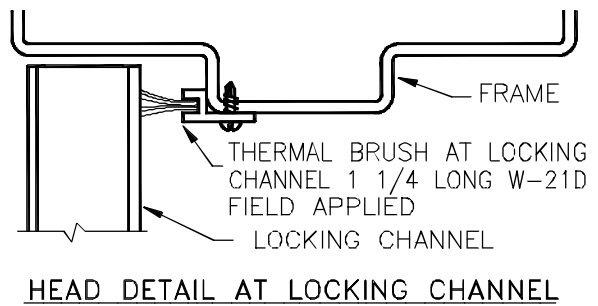
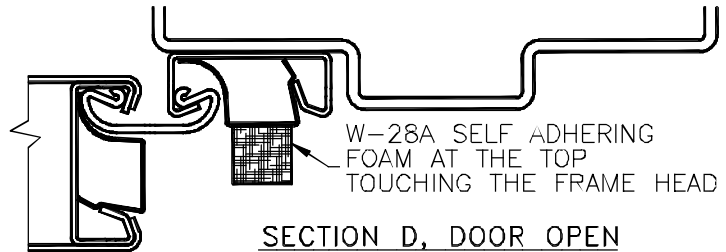

**Total Door** SYSTEMS™  
Global Leader in Integrated Access Technology™

TEL. (800) 852-6660  
www.totaldoor.com  
© Total Door 2017

FILE NAME
TDS3-01
DATE 5/4/17

# TECHNICAL DATA SHEET # 2A 01

## PAIRS OF DOORS – HEAD STRIKE WEATHER SEALING

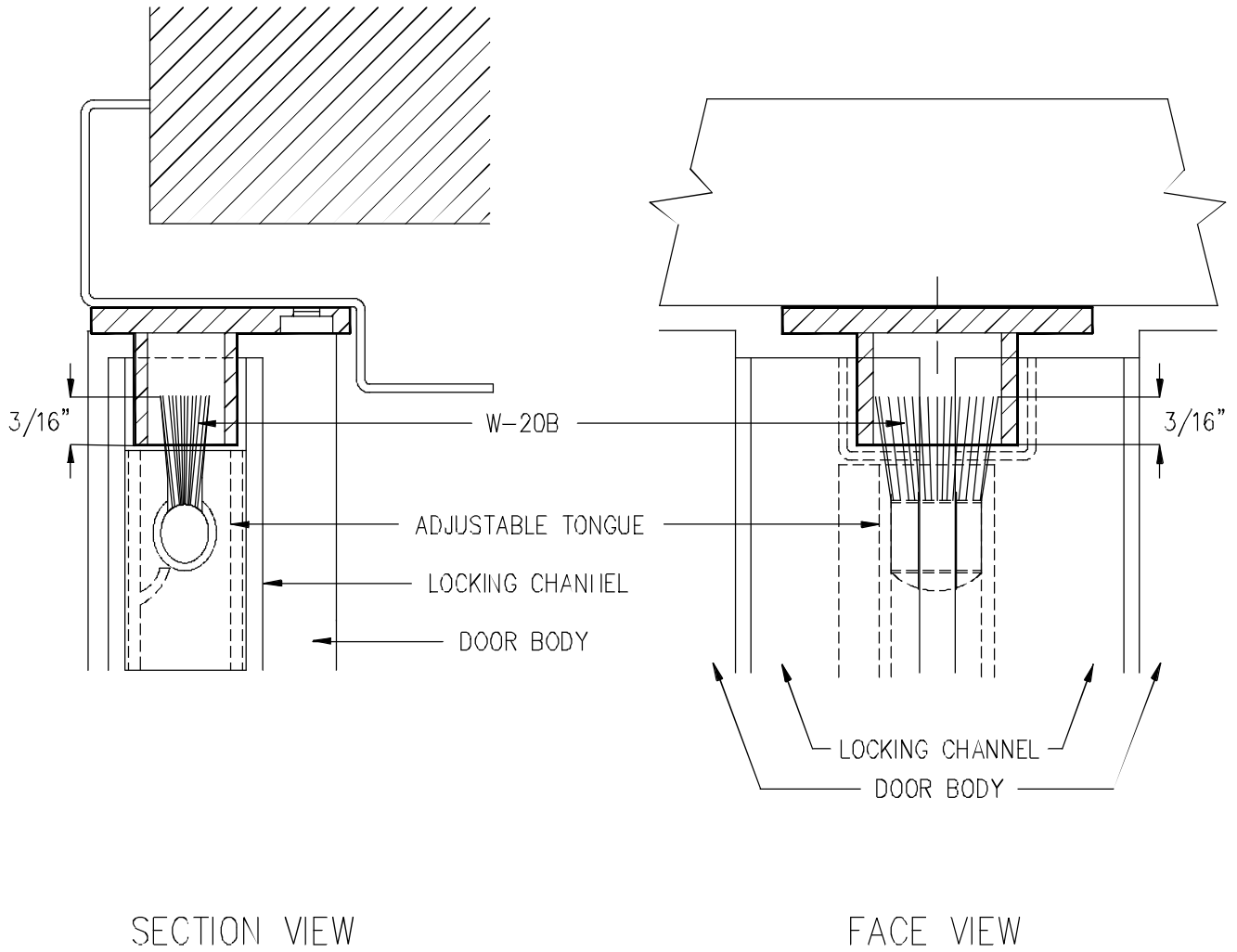

AFTER MOUNTING THE DOORS AND HEAD STRIKE ACCORDING TO TDS#2, INSTALL THE WEATHER SEAL W-20B INTO THE STIFFENER TUBE OF THE ADJUSTABLE TONGUE. CLOSE DOOR TO TEST FIT. CUT BRUSH FOR A 3/16" PROJECTION UP IN THE CENTER OF HEAD STRIKE. ONCE FIT IS CORRECT, REMOVE AND ADD SILICONE TO THE BASE AND RE-INSERT BACK INTO STIFFENER TUBE TO SECURE.



**Total Door** SYSTEMS™  
Global Leader in Integrated Access Technology™

TEL. (800) 852-6660  
www.totaldoor.com  
© Total Door 2015

FILE NAME
TDS2A-01
DATE 8/10/15

# TECHNICAL DATA SHEET # 40

## H-17 HANGER ROD INSTALLATION INSTRUCTIONS

### HANGER ROD INSTALLATION

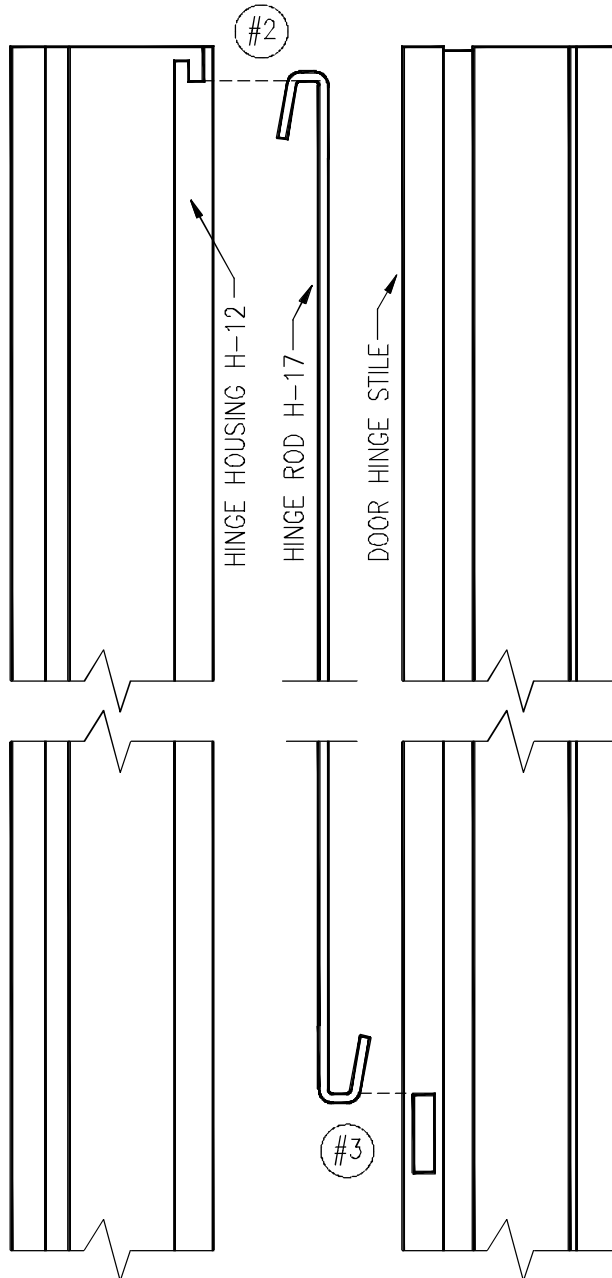

#1 DO NOT OPEN UP THE HOOK

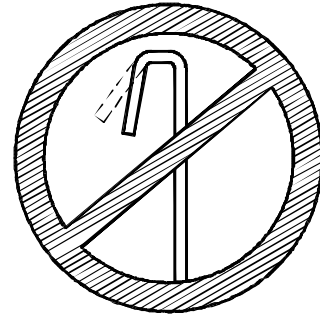

OPENING UP HANGER ROD WILL CAUSE FAILURE.

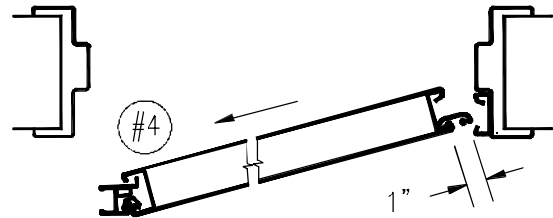

- #2 ENGAGE THE HANGER ROD IN THE SLOT IN THE HINGE HOUSING H-12 WITH THE DOOR IN POSITION AS SHOWN
- #3 TILT THE TOP OF THE DOOR AWAY FROM THE HINGE JAMB TO RAISE THE HINGE STILE. THEN ENGAGE THE HANGER ROD IN THE HINGE STILE WITHOUT OPENING THE HOOK ANGLE. DO NOT ALLOW THE END OF THE HOOK TO TOUCH THE TOP OF THE SLOT IN THE HINGE STILE OR HANGER ROD BREAKAGE MAY OCCUR.
- #4 WHEN DOING THE ABOVE DO NOT PULL DOOR AWAY FROM THE JAMB BY MORE THAN 6". THIS CAN CAUSE HANGER ROD FAILURE.

NOTE: IF REPLACING H-17 WITH H-50  
HINGE HOUSING H-12 AND HINGE H-13  
MUST BE REPLACED

# TECHNICAL DATA SHEET # 40B

## H-50 HANGER ROD INSTALLATION INSTRUCTIONS

### HANGER ROD INSTALLATION

#1 DO NOT OPEN UP THE HOOK

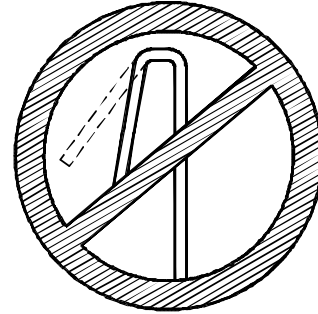

OPENING UP HANGER ROD WILL CAUSE FAILURE.

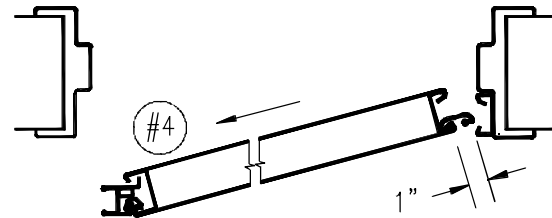
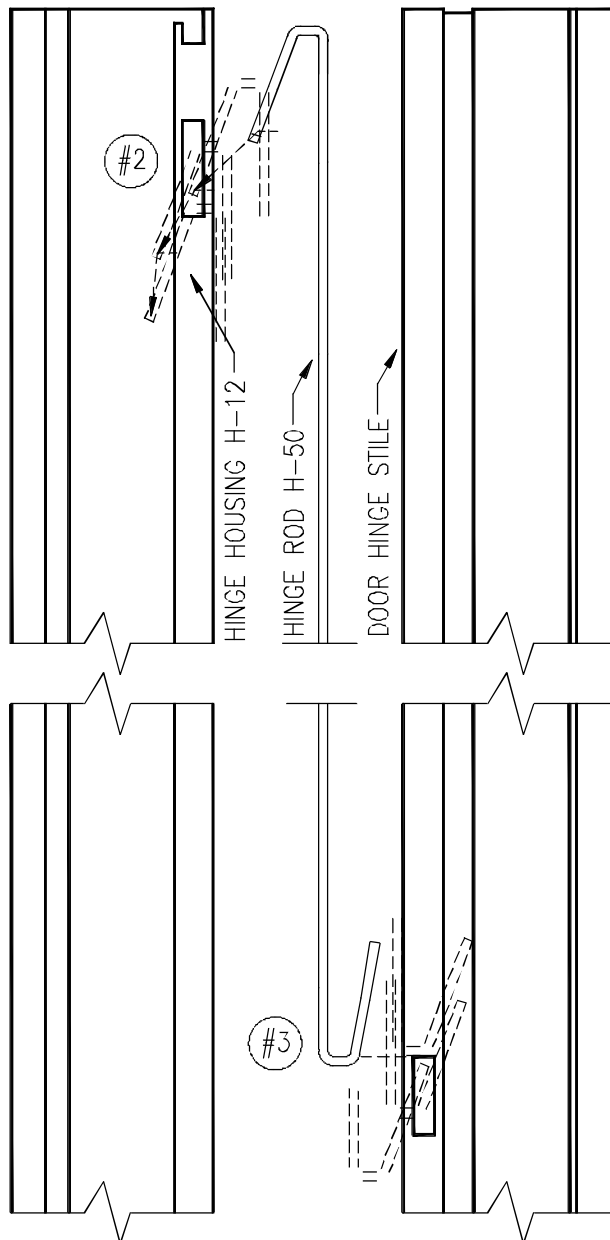

- #2 ENGAGE THE HANGER ROD IN THE SLOT IN THE HINGE HOUSING H-12 WITH THE DOOR IN POSITION AS SHOWN
- #3 TILT THE TOP OF THE DOOR AWAY FROM THE HINGE JAMB TO RAISE THE HINGE STILE. THEN ENGAGE THE HANGER ROD IN THE HINGE STILE WITHOUT OPENING THE HOOK ANGLE. DO NOT ALLOW THE END OF THE HOOK TO TOUCH THE TOP OF THE SLOT IN THE HINGE STILE OR HANGER ROD BREAKAGE MAY OCCUR.
- #4 WHEN DOING THE ABOVE DO NOT PULL DOOR AWAY FROM THE JAMB BY MORE THAN 6". THIS CAN CAUSE HANGER ROD FAILURE.



**Total Door** SYSTEMS™  
Global Leader in Integrated Access Technology™

TEL. (800) 852-6660  
www.totaldoor.com  
© Total Door 2013

FILE NAME
TDS40B
DATE 8/30/13

# TECHNICAL DATA SHEET # 1A

02

## DOOR HINGE STILE - PART NAMES AND NUMBERS

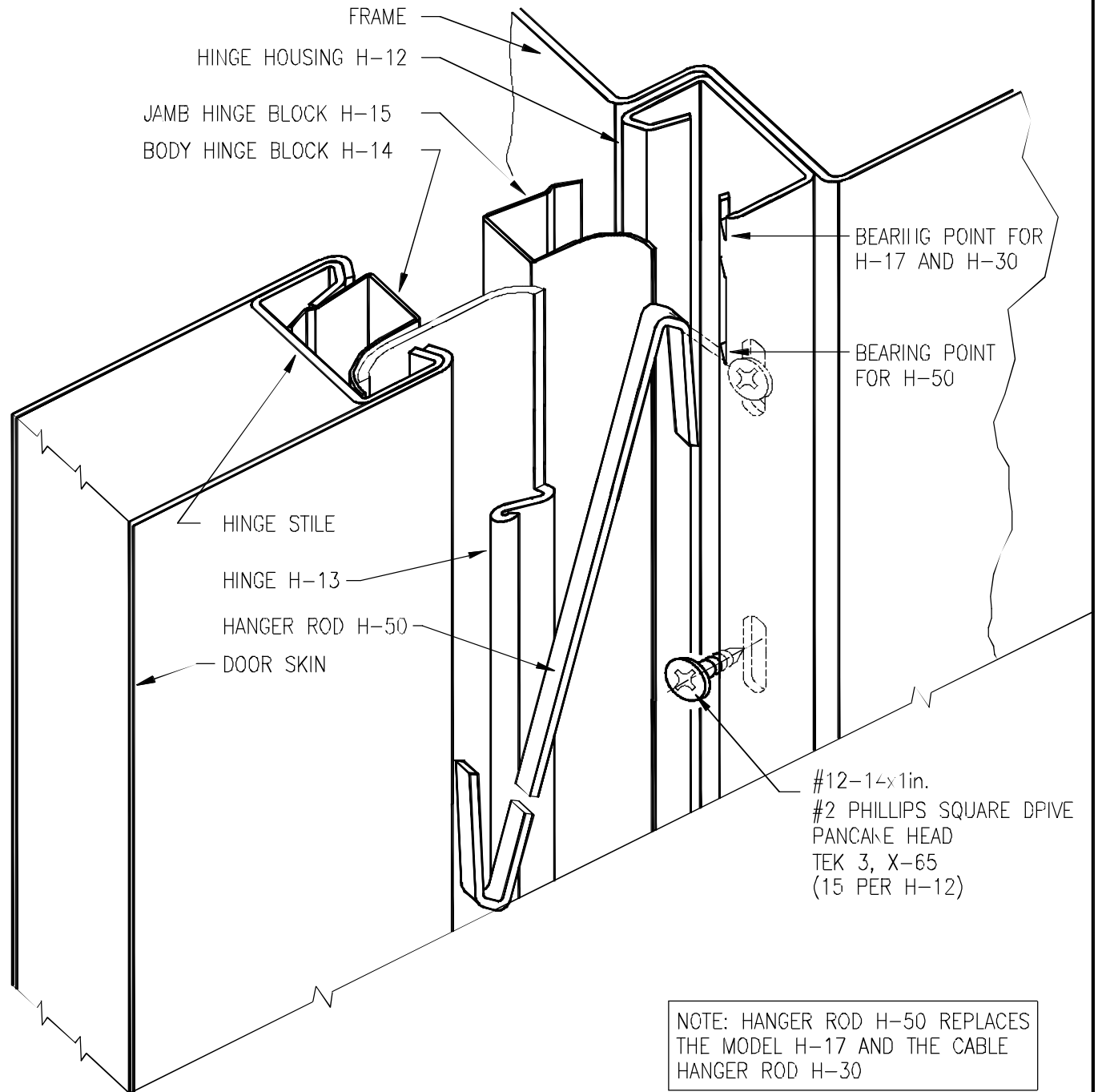

# TECHNICAL DATA SHEET # 29

01

## APPARENT PIVOT POINT OF TOTAL-DOOR® HINGE

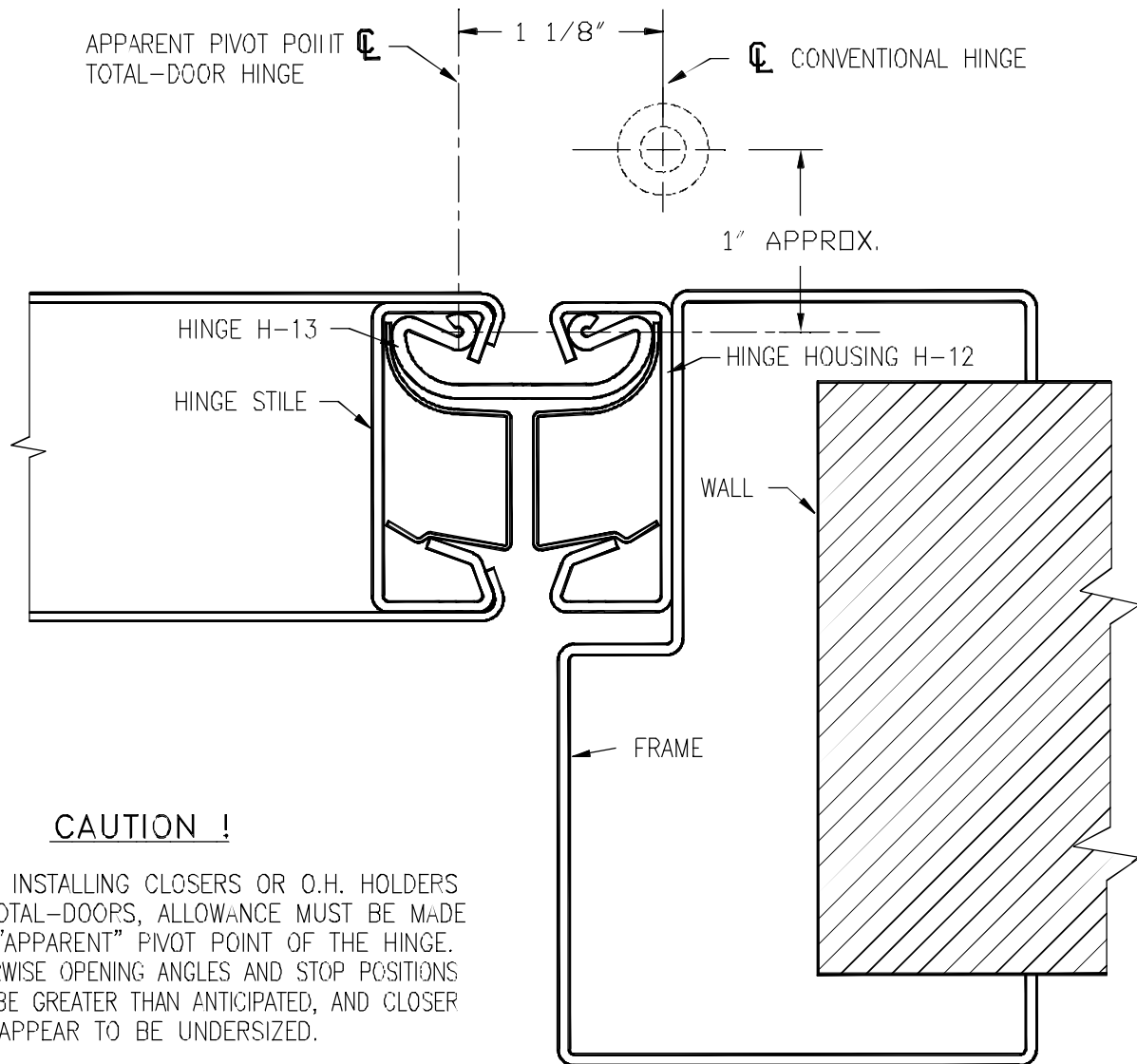

### CAUTION !

WHEN INSTALLING CLOSERS OR O.H. HOLDERS ON TOTAL-DOORS, ALLOWANCE MUST BE MADE FOR "APPARENT" PIVOT POINT OF THE HINGE. OTHERWISE OPENING ANGLES AND STOP POSITIONS WILL BE GREATER THAN ANTICIPATED, AND CLOSER WILL APPEAR TO BE UNDERSIZED.



**Total Door** SYSTEMS™  
Global Leader in Integrated Access Technology™

TEL. (800) 852-6660

[www.totaldoor.com](http://www.totaldoor.com)

© Total Door 2013

FILE NAME

TDS29-01

DATE 8/30/13



# TECHNICAL DATA SHEET # 52

05

## RIGIDIZED HINGE – FIELD MODIFICATION

### FIELD INSTALLATION INSTRUCTIONS

- 1) REMOVE DOOR FROM THE OPENING.
- 2) REMOVE HINGE STOP (B-28) AND SLIDE RIGID INSERT (H-90) UP BETWEEN HINGE (H-13) AND THE BODY HINGE STILE AS SHOWN IN THE ILLUSTRATION BELOW.
- 3) REINSTALL HINGE STOP (B-28) & REINSTALL DOOR IN OPENING.

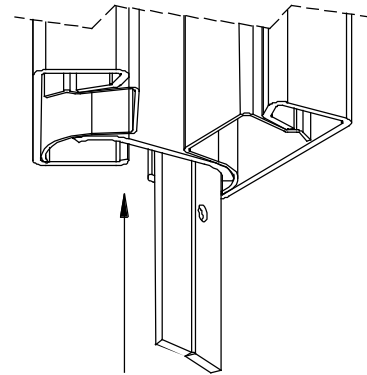

UP FROM BOTTOM OF DOOR

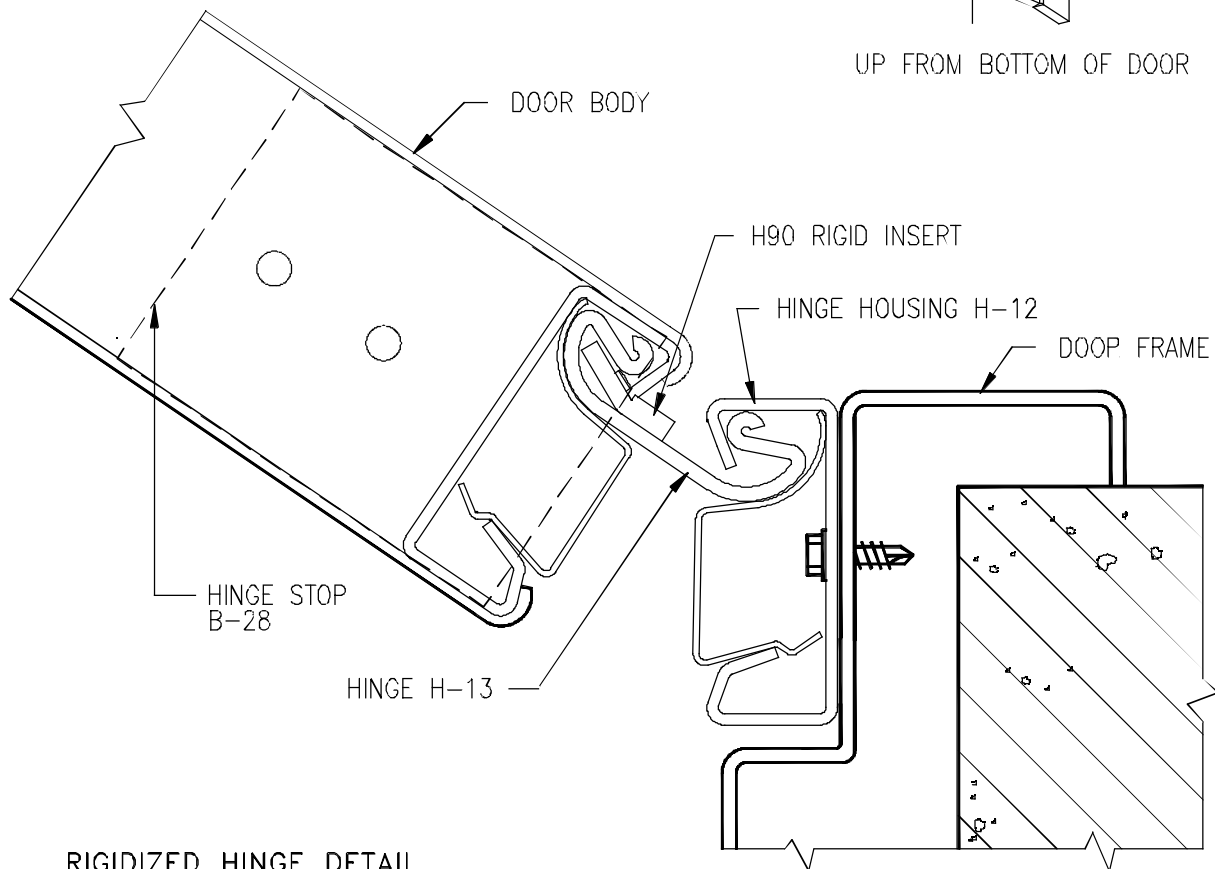

RIGIDIZED HINGE DETAIL

# TECHNICAL DATA SHEET # 36

02

## TOTAL-DOOR INSTALLATION "KEY"

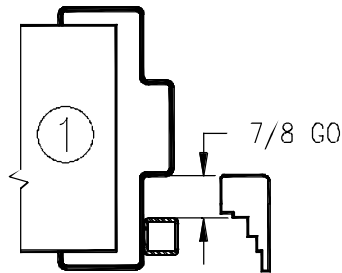

**LATCH STOP TO FRAME STOP**  
USE 7/8 PORTION OF "KEY" TO CHECK PROPER STOP POSITION

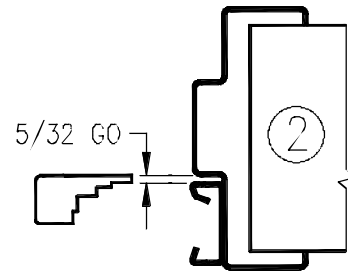

**HINGE HS'G TO FRAME STOP**  
USE 5/32 PORTION OF "KEY" TO CHECK FOR MINIMUM CLEARANCE AT TOP OF JAMB.

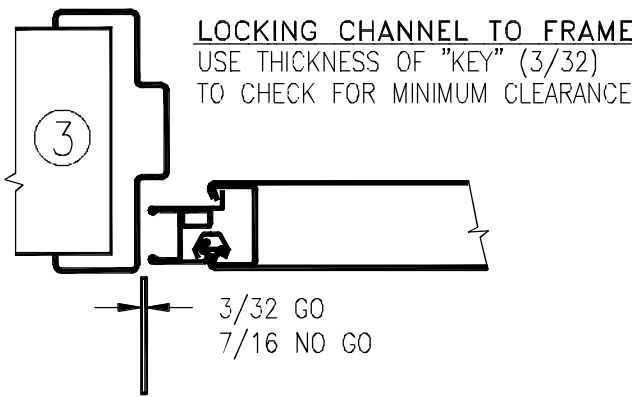

**LOCKING CHANNEL TO FRAME**  
USE THICKNESS OF "KEY" (3/32) TO CHECK FOR MINIMUM CLEARANCE

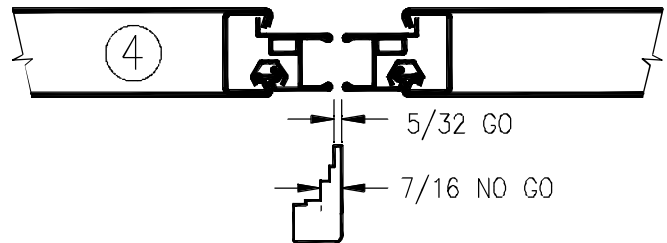

**LOCKING CHANNEL OF PAIRS**  
USE 5/32 PORTION OF "KEY" TO CHECK FOR MINIMUM CLEARANCE BETWEEN LOCKING CHANNELS. MEASURE PULL SIDE ONLY.

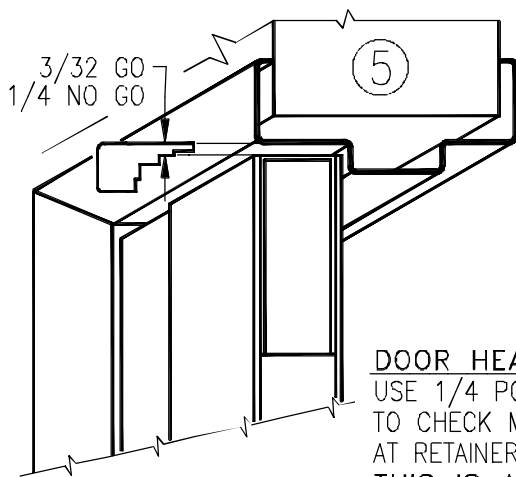

**DOOR HEAD TO FRAME**  
USE 1/4 PORTION OF "KEY" TO CHECK MAXIMUM CLEARANCE AT RETAINER.  
THIS IS A NO GO CHECK.

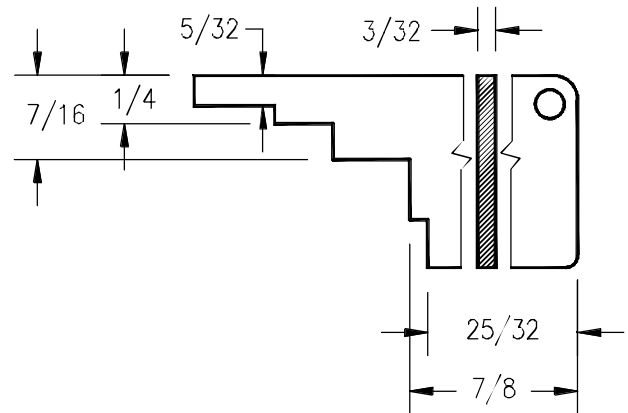

**TOTAL-DOOR INSTALLATION "KEY"**  
CHECKING OF INSTALLATION WITH THIS "KEY" WILL ASSURE SMOOTH, TROUBLE FREE OPERATION.

# TECHNICAL DATA SHEET # 5

01

## DOUBLE EGRESS PAIR DETAIL

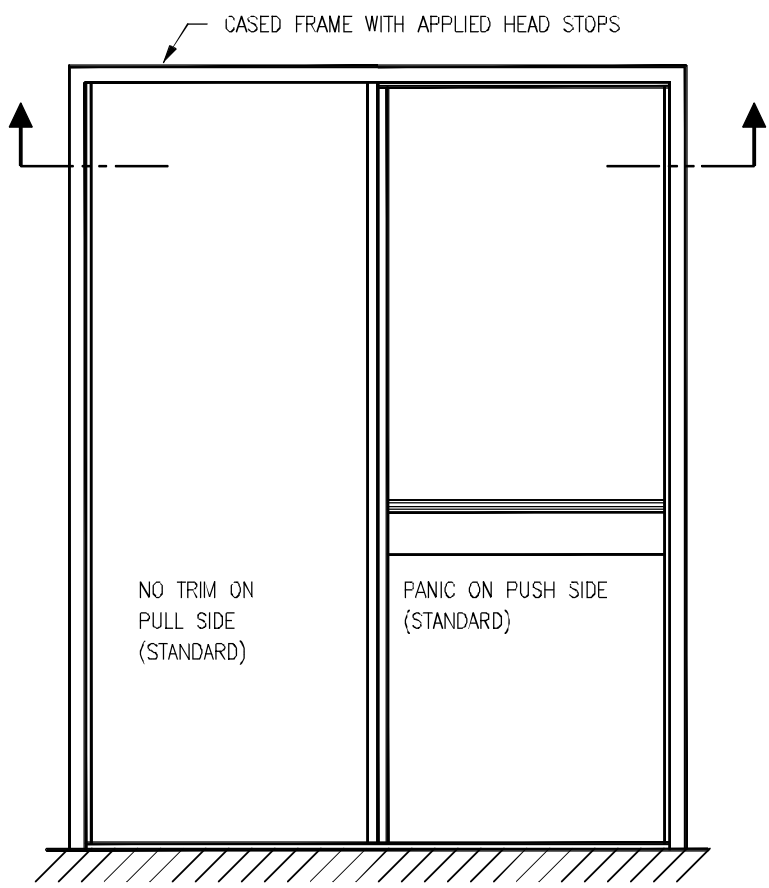

ELEVATION (RIGHT HAND TRAFFIC SHOWN)

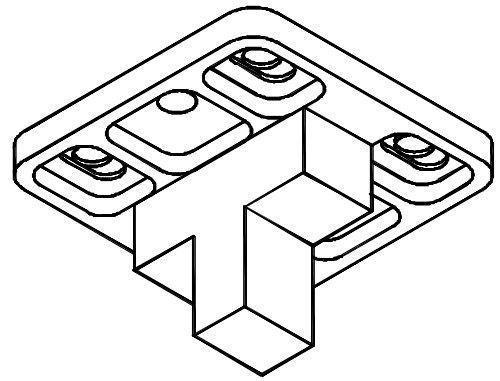

L-47 HEAD STRIKE

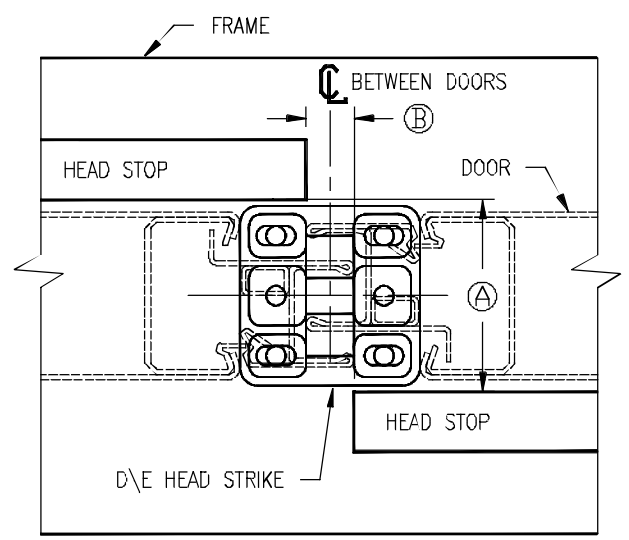

DETAIL REFLECTED VIEW OF DOUBLE EGRESS HEAD STRIKE

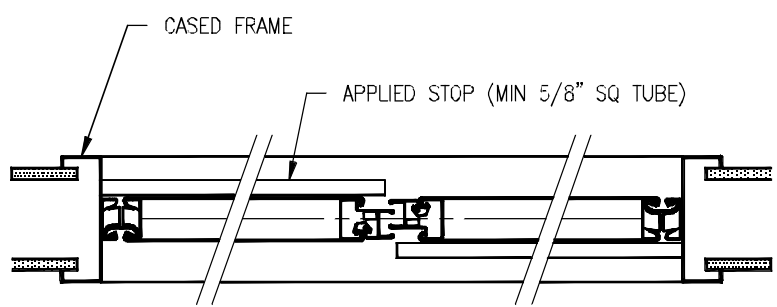

REFLECTED PLAN VIEW

NOTE: IF DOORS WILL BE INSTALLED IN AN EXISTING TRIPLE STEP DOUBLE EGRESS FRAME, THIS MUST BE NOTED ON THE ORDER SO THAT SPECIAL MODIFICATIONS CAN BE MADE TO THE HEAD STRIKE AND LOCKING CHANNEL. REFER TO TECH DATA SHEET #70

DIMENSION Ⓑ MUST BE 1/2"±1/32"  
 DIMENSION Ⓐ MUST BE 2" FOR PAINTED STEEL DOORS & 2 1/8" FOR DOORS WITH WOOD VENEER OR OTHER SURFACE APPLIED FINISHES

# TECHNICAL DATA SHEET # 70

01

## D/E L-11 PREPARATION FOR 3-STEP FRAME

**NOTE:** TOTAL DOOR SYSTEMS MUST BE TOLD IF THE TOTAL-DOOR IS TO BE INSTALLED INTO A NEW OR EXISTING TRIPPLE STEPPED DOUBLE EGRESS FRAME AS OPPOSED TO OUR CUSTOMARY PLAIN CASED DOUBLE EGRESS FRAME. THIS SITUATION REQUIRES A DOUBLE EGRESS LOCKING CHANNEL SHORTENED BY AN ADDITIONAL 1/2" AND A HEAD STRIKE WHICH IS 1/2" TALLER. THIS ALLOWS THE LOCKING CHAINEL TO CLEAR THE HEAD STOPS WHICH DO NOT STOP 1/8" SHORT OF THE FRAME CENTERLINE.

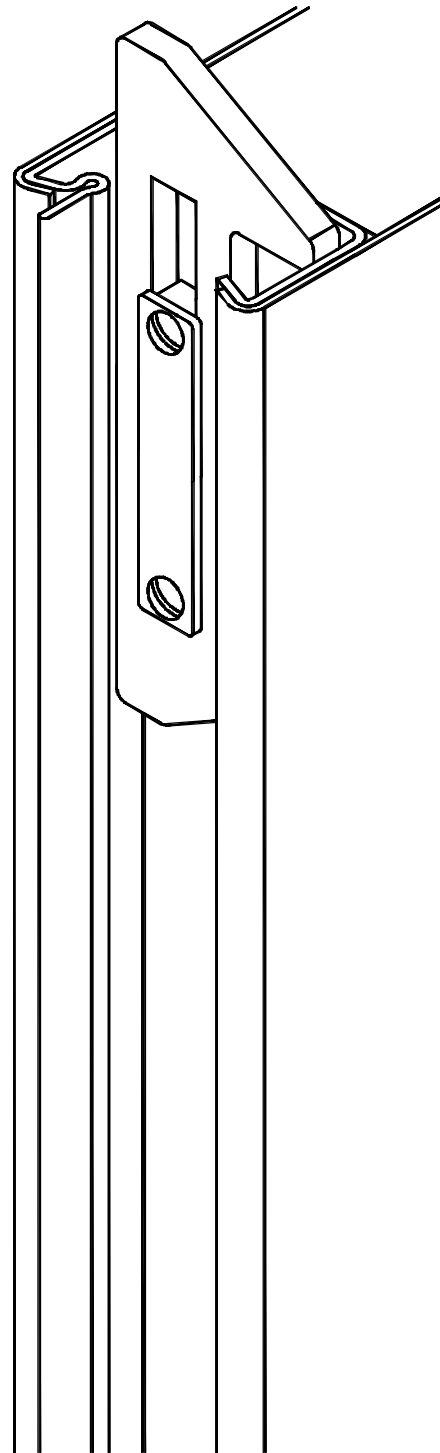
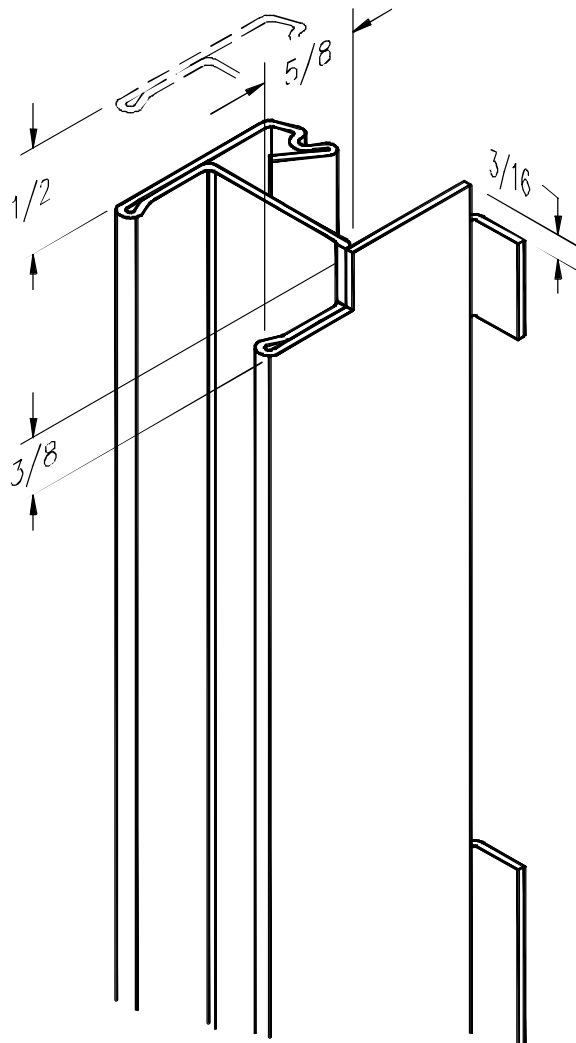

**Total Door** SYSTEMS™  
Global Leader in Integrated Access Technology™

TEL. (800) 852-6660

[www.totaldoor.com](http://www.totaldoor.com)

© Total Door 2013

FILE NAME

TDS70-01

DATE 8/30/13

# TECHNICAL DATA SHEET # 17

01

## HELPER SPRING MOUNTING DETAIL

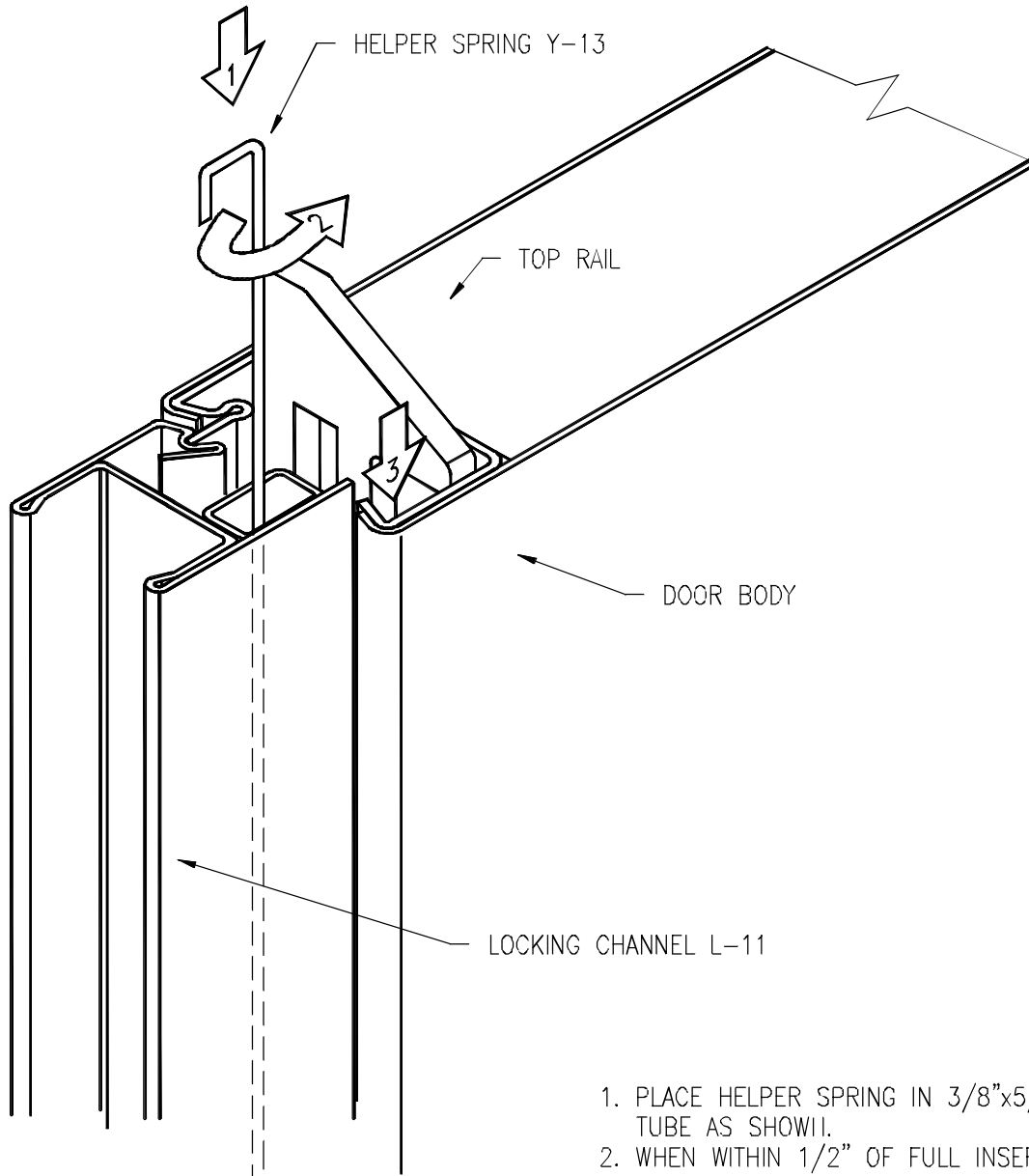

1. PLACE HELPER SPRING IN 3/8"x5/8" STIFFENER TUBE AS SHOWN.
2. WHEN WITHIN 1/2" OF FULL INSERTION, ROTATE APPROX. 180° TOWARD PUSH SIDE OF DOOR.
3. WHILE IN TORQUED POSITION, INSERT BEHIND LIP OF STILE BY PUSHING DOWN.



**Total Door** SYSTEMS™  
Global Leader in Integrated Access Technology™

TEL. (800) 852-6660

[www.totaldoor.com](http://www.totaldoor.com)

© Total Door 2013

FILE NAME

TDS17-01

DATE 8/30/13

# TECHNICAL DATA SHEET # 1C 01

## DOOR LATCH STILE - PART NAMES AND NUMBERS

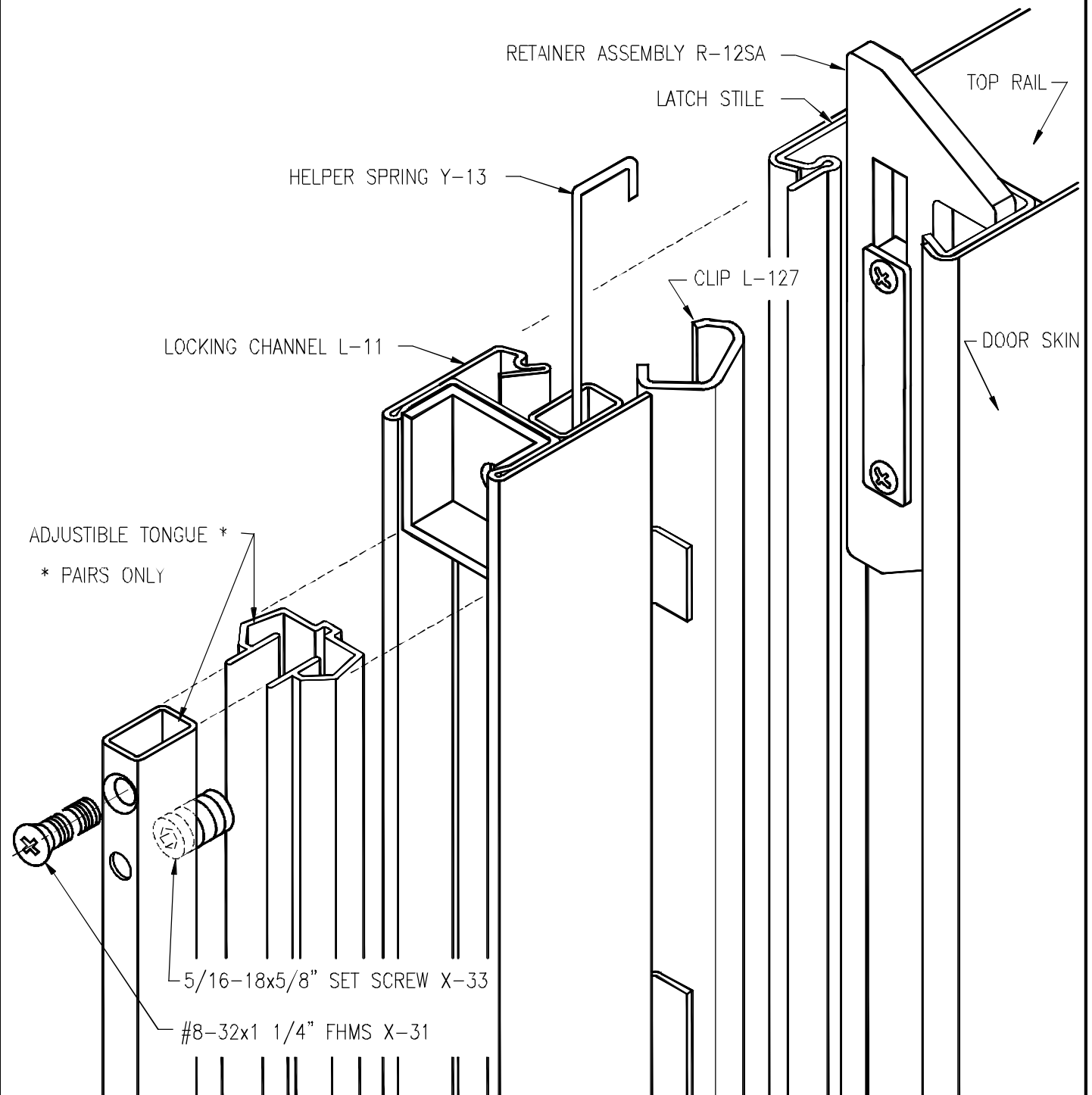

**Total Door** SYSTEMS™  
Global Leader in Integrated Access Technology™

TEL. (800) 852-6660  
www.totaldoor.com  
© Total Door 2013

FILE NAME
TDS1C-01
DATE: 8/30/13

# TECHNICAL DATA SHEET # 1D

02

## ONE PIECE LATCH STOP L-55

NOTE: FAILURE TO FOLLOW THESE INSTRUCTIONS WILL RESULT IN DOORS NOT LATCHING, NOT LOCKING, OR BEING DIFFICULT TO OPEN OR CLOSE

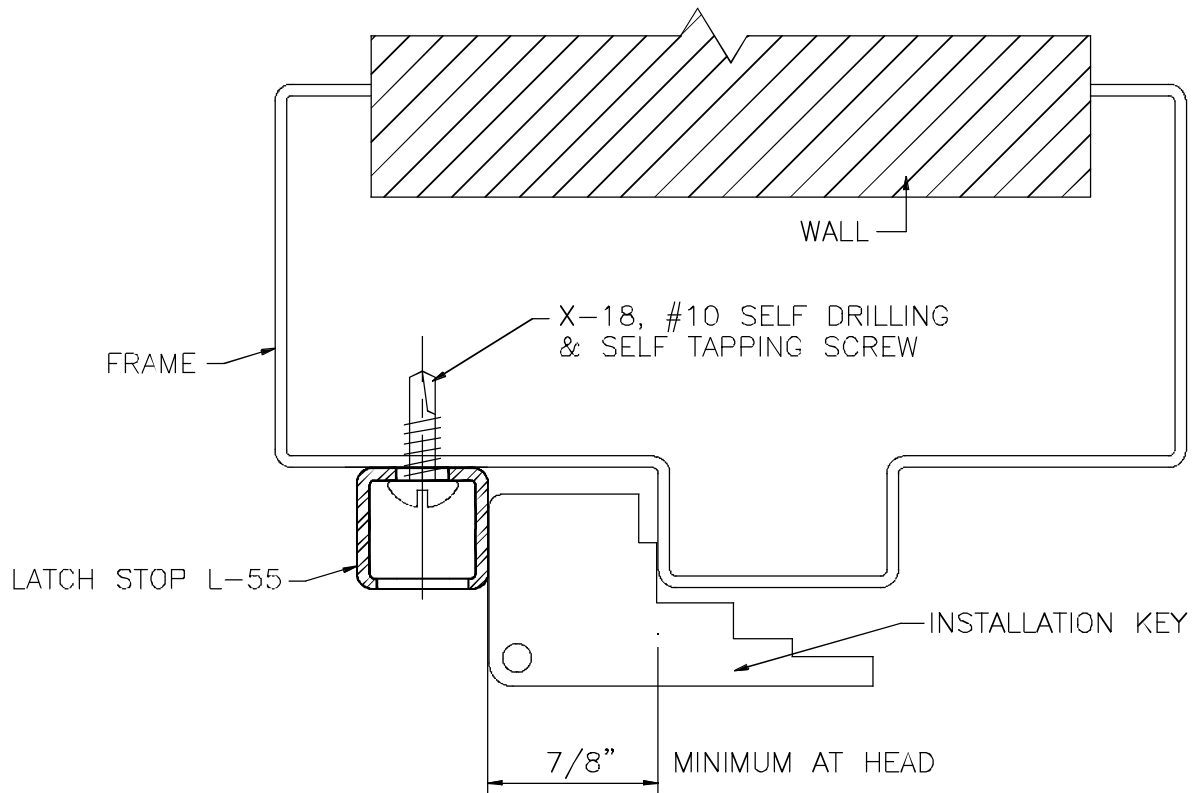

### LATCH STOP L-55, INSTALLATION PROCEDURE

1. Install top screw of latch stop L-55, with the back side 7/8" from the frame rabbet. Use the installation key provided to insure correct tolerances.
2. Depress the retainer on the top of the door and rotate the locking channel L-11 to the locked position. Close the door firmly against the latch stop L-55. Press the L-55 against the locking channel L-11 and scribe a line on the jamb the length of the L-55 on the rabbet side.
3. With the L-55 on the scribed line, install the bottom and middle screws.
4. Test the door for proper operation. If the door operates smoothly and easily, install the balance of the screws and nylon hole plugs.



**Total Door** SYSTEMS™  
Global Leader in Integrated Access Technology™

TEL. (800) 852-6660  
www.totaldoor.com  
© Total Door 2015

FILE NAME
TDS1D-02
DATE 3/18/15

# TECHNICAL DATA SHEET # 21

01

## LOCKING CHANNEL - PARTS NAMES AND NUMBERS

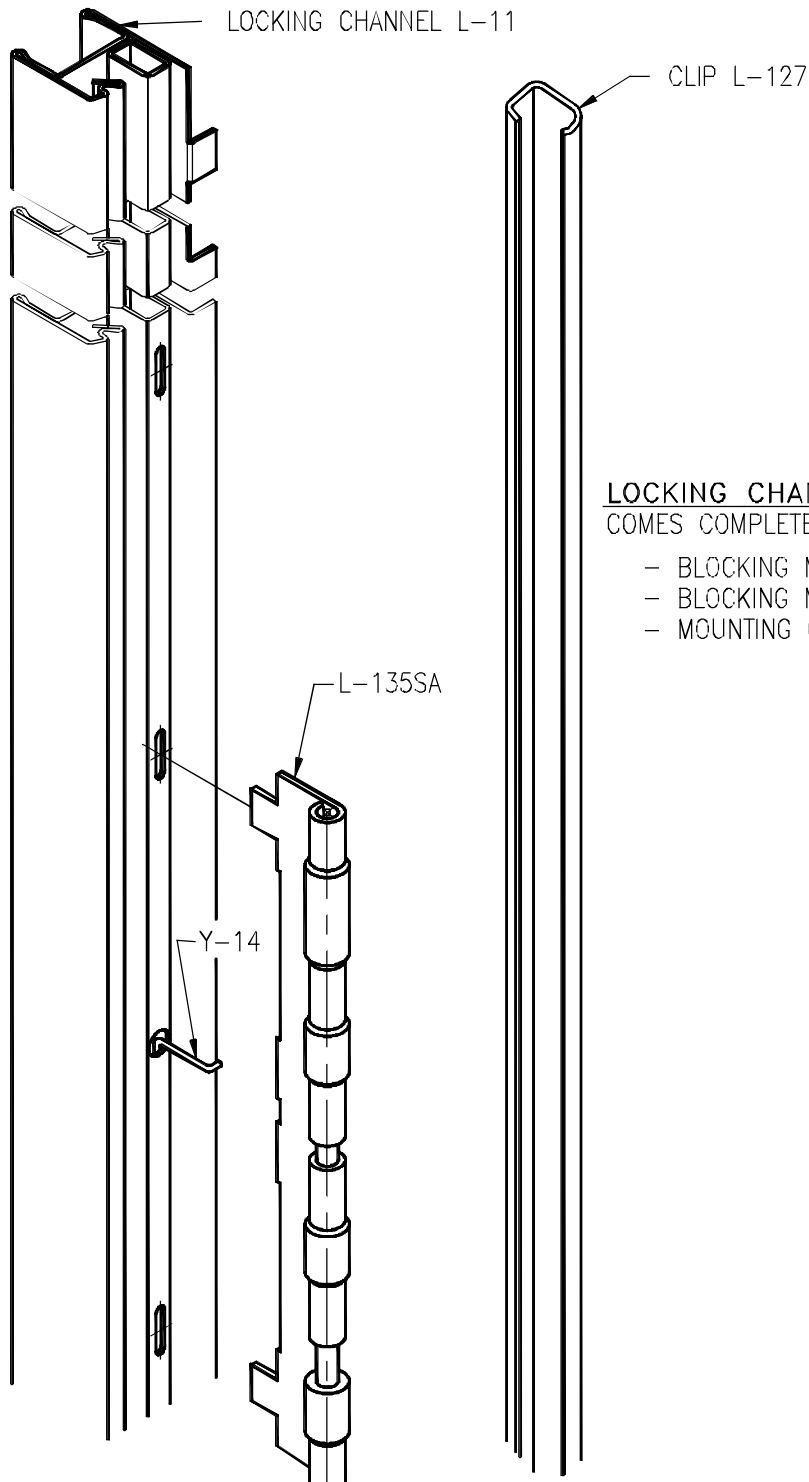

### LOCKING CHANNEL L-11 ASSEMBLY COMES COMPLETE WITH:

- BLOCKING MEMBER SUBASSEMBLY L-135SA
- BLOCKING MEMBER SPRING Y-14
- MOUNTING CLIP L-127



**Total Door** SYSTEMS™  
Global Leader in Integrated Access Technology™

TEL. (800) 852-6660

[www.totaldoor.com](http://www.totaldoor.com)

© Total Door 2013

FILE NAME

TDS21-01

DATE 8/30/13



# TECHNICAL DATA SHEET # 13

02

## REMOVABLE MULLION DETAILS

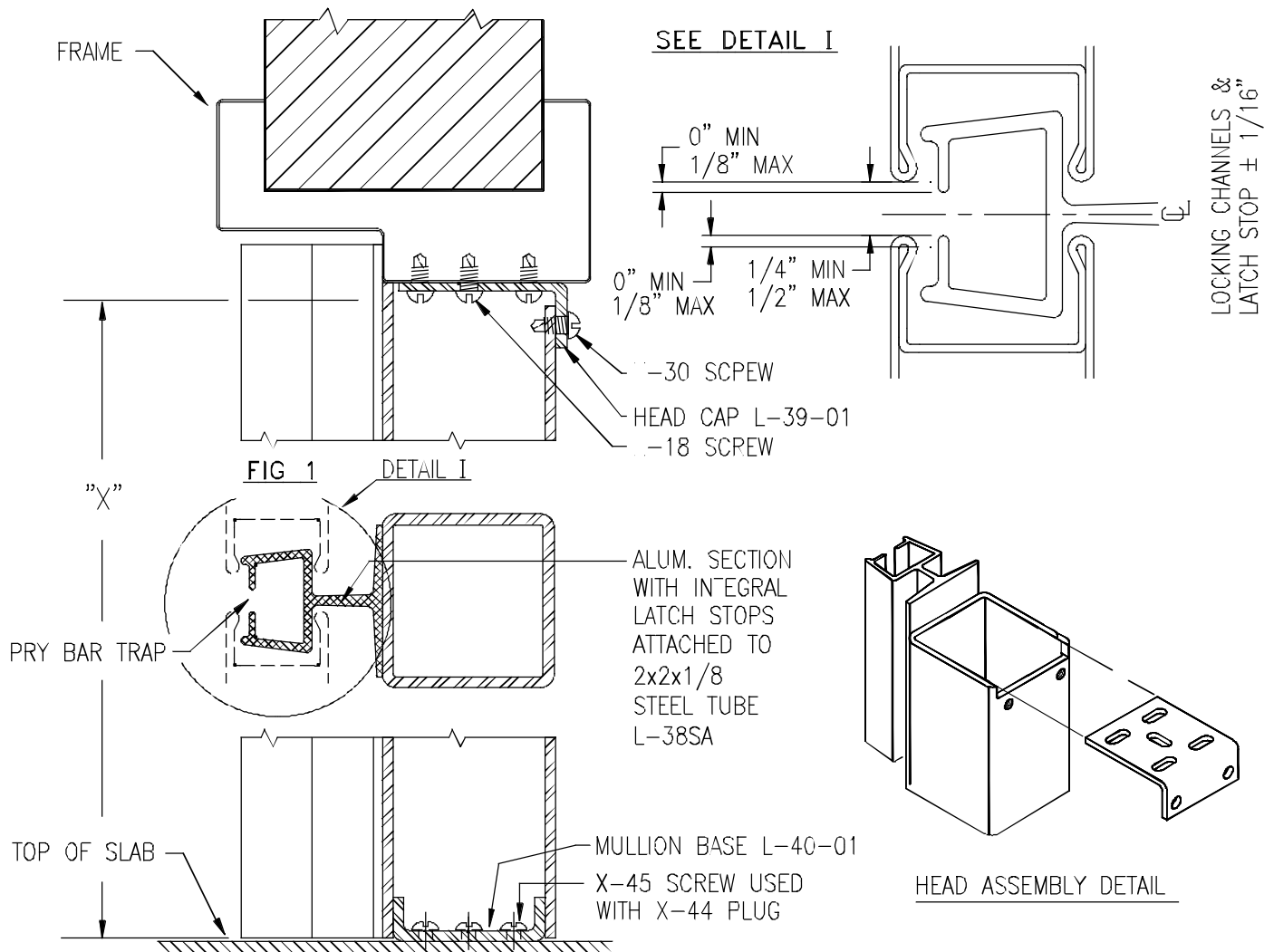

FIG 2 - FOOT DETAIL WITHOUT THRESHOLD

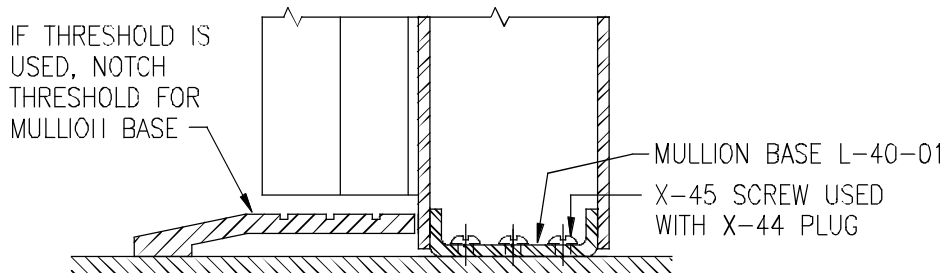
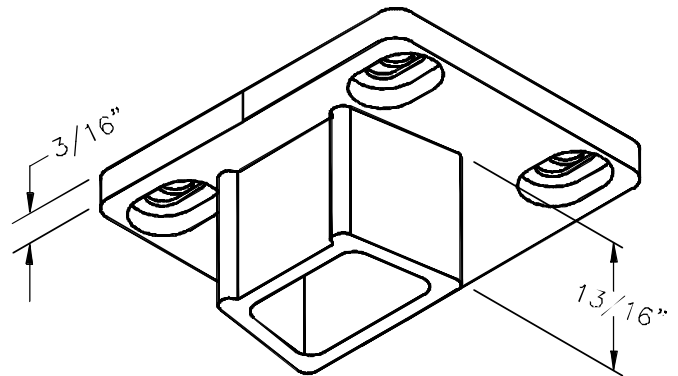
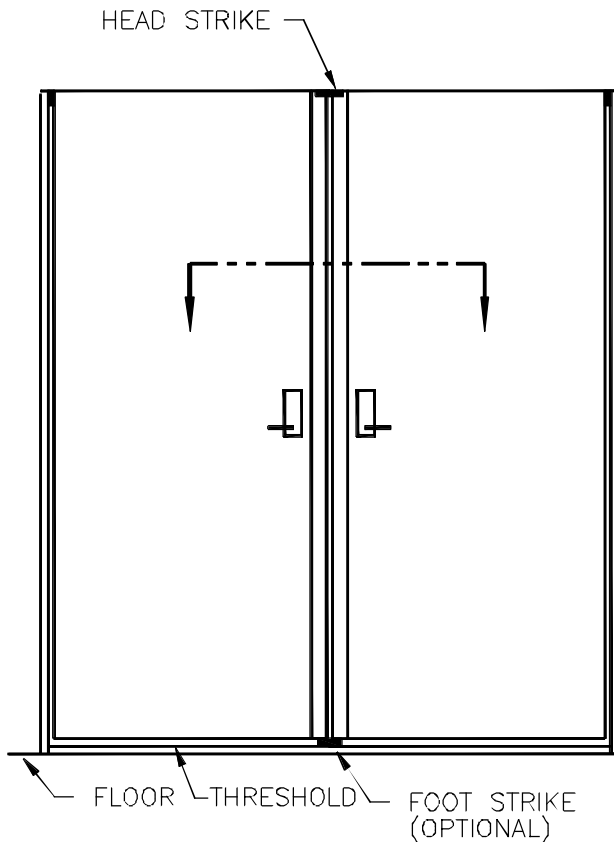

FIG 3 - FOOT DETAIL WITH THRESHOLD

# TECHNICAL DATA SHEET # 2

01

## STANDARDS FOR PAIRS OF DOORS



L-45 HEAD STRIKE - BRONZE

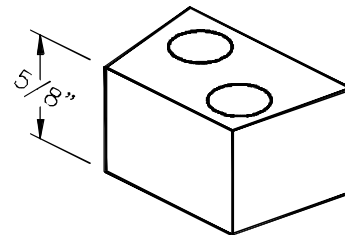

L-46A FOOT STRIKE - BRASS

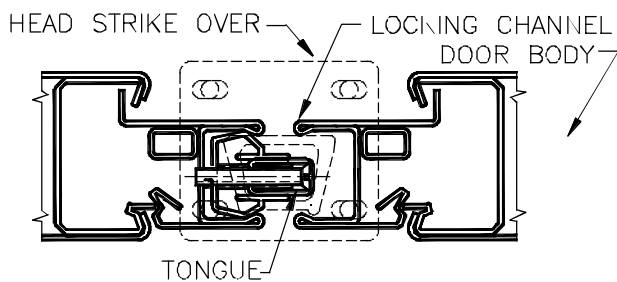

### SECTION THRU LATCH STILES

#### TONGUE ADJUSTMENT:

TO MOVE TONGUE FURTHER OUT OF IT'S LOCKING CHANNEL L-11:

- BACK OUT PHILLIPS SCREW
- TIGHTEN ALLEN SET SCREW NEXT TO PHILLIPS SCREW

FOOT STRIKES ARE NOT REQUIRED FOR LABEL OR NON-LABEL DOORS, BUT ARE RECOMMENDED ON IN SWINGING, HIGH SECURITY DOORS.

### NOTES

#### SCREWS:

STRIKES ARE MOUNTED WITH #10 5/8", #3 TEK, PAN HEAD SCREWS (SELF DRILLING & SELF-TAPPING) X-18

#### TONGUE:

THE R.H. OR L.H.R. DOOR OF A PAIR IS PROVIDED WITH AN ADJUSTABLE TONGUE TO ACCOMODATE FRAME VARIATIONS OF  $\pm 1/16"$

#### ALIGNMENT:

PAIRS OF DOORS MUST HAVE BOTH LATCH STILES IN PLANE. WITHIN 1/8". MISALIGNMENT OVER 1/8" WILL RESULT IN HIGH MAINTENANCE AND LOSS OF SECURITY.

#### INSTALLATION:

THE HEAD & FOOT STRIKE MUST BE CENTERED  $\pm 1/32"$  BETWEEN THE 2 DOORS, THE SMALL FACE OF THE STRIKE MUST BE ON THE PULL SIDE OF THE DOOR.

# TECHNICAL DATA SHEET # 25

05

## CYLINDER STANDARDS & MODIFICATIONS FOR FUNCTIONS 07, 09 & E-SAF

### FOR LEVER MECHANISMS

MINIMUM CYLINDER LENGTH = 1-1/8", MAXIMUM = 1-3/8"

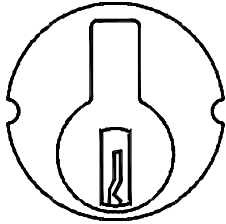

**LEVER LOCKS:**  
THE STANDARD CAM MUST BE USED

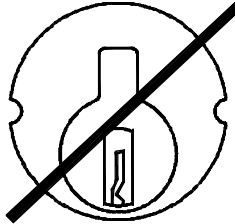

IF SHORTER OR LONGER CAMS ARE USED, THEY WILL NOT OPERATE THE MECHANISM.

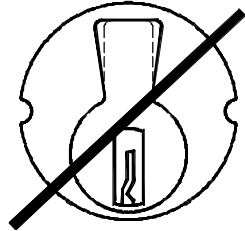

INDUSTRY STANDARD CAMS WHICH ARE FLARED, SHOULD NOT BE USED

**LEVER FLUSH PANIC LOCK:**  
THE STANDARD C4 CAM MUST BE USED

### FOR PUSH-PULL GRIPS

MINIMUM CYLINDER LENGTH = 7/8", MAXIMUM = 1-3/8"

THE SECOND MOST COMMON CAM IN THE INDUSTRY IS KNOWN AS THE A/R CAM. THIS CAM MUST BE USED WITH PUSH-PULL GRIPS. NO OTHER CAM WILL WORK.

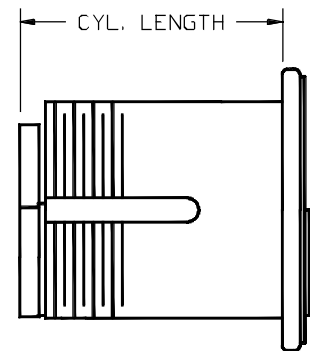
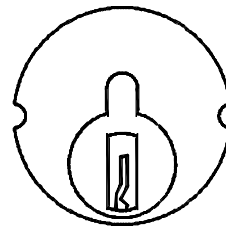

CYLINDER MODIFICATION FOR LOCK FUNCTIONS L07 L09 LP07  
REVERSE PROCEDURE FOR E-SAF LOCKS AND KEY UNLATCHING.

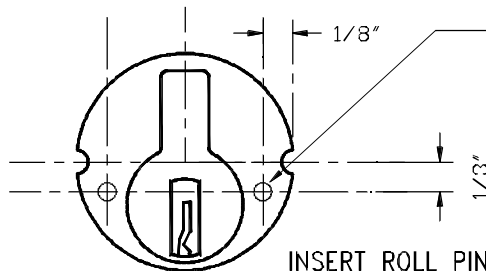

INSERT ROLL PIN IN:  
LEFT HOLE FOR LH & LHR DOOR.  
RIGHT HOLE FOR RH & RHR DOOR.

DRILL 1EA.  $\varnothing 3/32$ " HOLE,  
1/4" DEEP FOR  $3/32$ " x  $3/8$ "  
ROLL PIN.

CYLINDER MODIFICATION FOR LOCK FUNCTIONS G07 G09 GP07

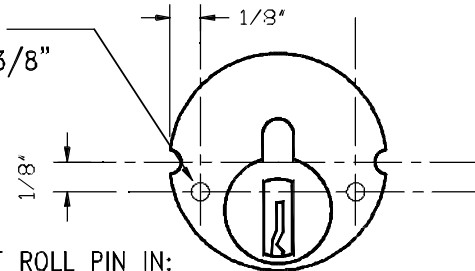

INSERT ROLL PIN IN:  
LEFT HOLE FOR RH & RHR DOOR.  
RIGHT HOLE FOR LH & LHR DOOR.

# TECHNICAL DATA SHEET # 51

01

## INSTALLATION OF ESCUTCHEONS WITH CONCEALED FASTENERS

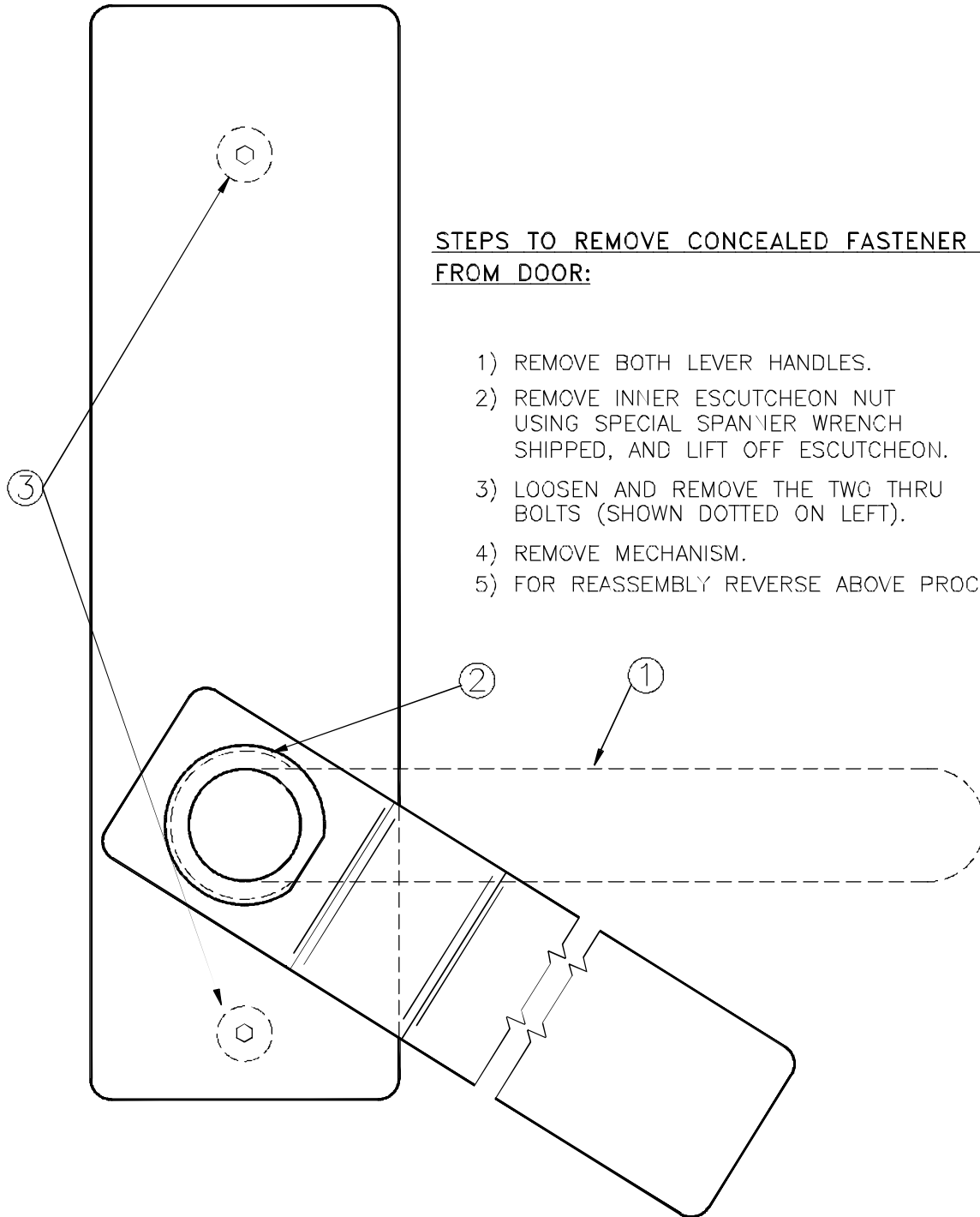

### STEPS TO REMOVE CONCEALED FASTENER MECHANISM FROM DOOR:

- 1) REMOVE BOTH LEVER HANDLES.
- 2) REMOVE INNER ESCUTCHEON NUT USING SPECIAL SPANNER WRENCH SHIPPED, AND LIFT OFF ESCUTCHEON.
- 3) LOOSEN AND REMOVE THE TWO THRU BOLTS (SHOWN DOTTED ON LEFT).
- 4) REMOVE MECHANISM.
- 5) FOR REASSEMBLY REVERSE ABOVE PROCEDURE.

# TECHNICAL DATA SHEET # 80

## LEVER DESIGNS #60, #82, #83 & #84

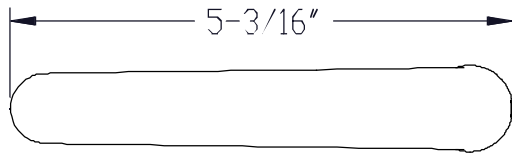

Q-60 LEVER DESIGN

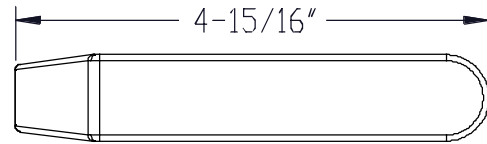

Q-82 LEVER DESIGN

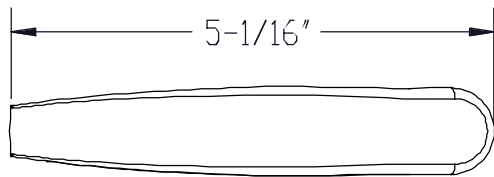
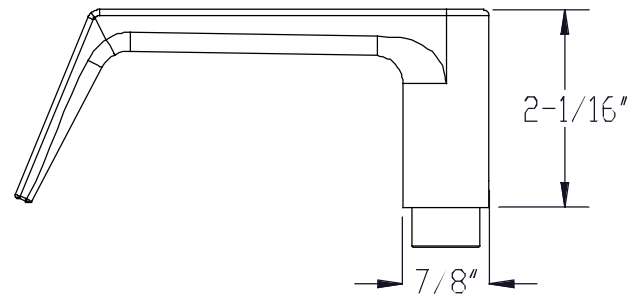
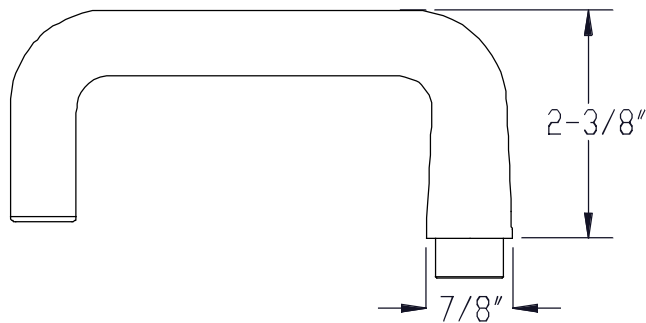

Q-83 LEVER DESIGN

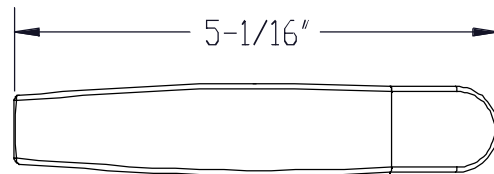

Q-84 LEVER DESIGN

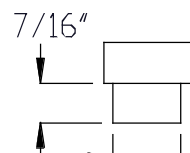
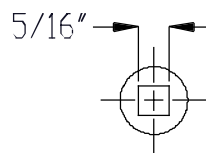
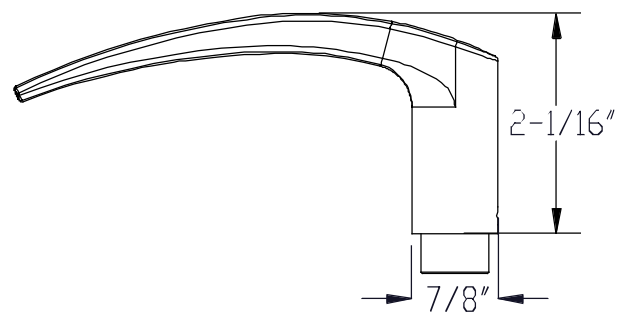
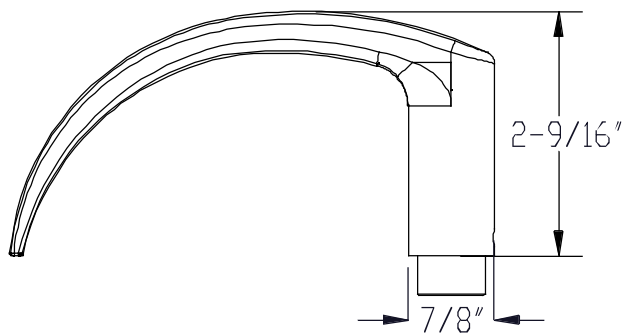

END VIEW OF LEVER'S

11/16"



**Total Door** SYSTEMS™  
Global Leader in Integrated Access Technology™

TEL. (800) 852-6660  
www.totaldoor.com  
© Total Door 2013

FILE NAME
TDS80
DATE: 05/5/12

# TECHNICAL DATA SHEET # 33

03

## SPINDLE FASTENING DETAIL

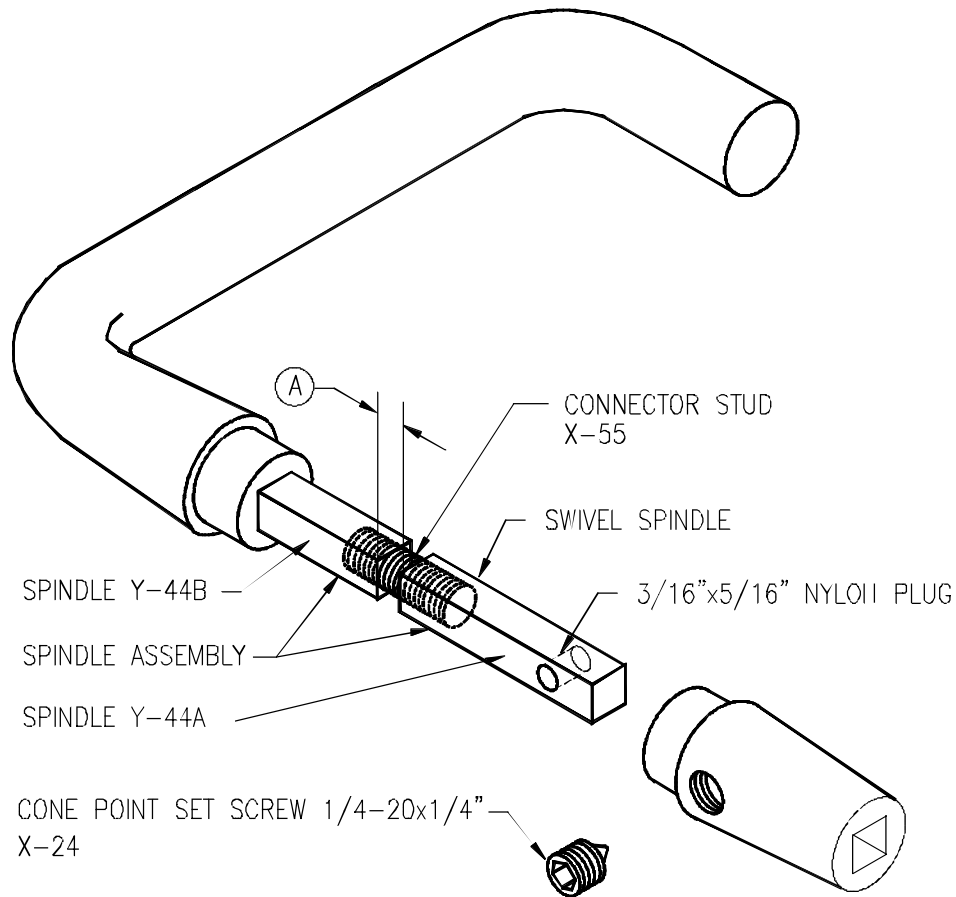

**(A) NOTE:** BACK OFF SPINDLE TO SUIT DOOR THICKNESS

THE NEW SPINDLE FASTENING MECHANISM FOR LEVERS IS PICTURED ABOVE.  
INSTALL AS FOLLOWS:

- A) TIGHTEN UP, THEN BACK OFF SWIVEL SPINDLE TO SUIT DOOR THICKNESS.
- B) INSERT LEVER FROM OUTSIDE. (NYLON PLUG MUST BE HORIZONTAL). PUSH ON INNER LEVER.
- C) CHECK THAT THE NYLON PLUG IS VISUALLY CENTERED ON THE SET SCREW HOLE. IF IT IS NOT, REMOVE OUTER LEVER AND SPINDLE AND ADJUST TO SUIT DOOR THICKNESS.
- D) REPEAT (B) AND (C)
- E) INSTALL SET SCREW.



**Total Door** SYSTEMS™  
Global Leader in Integrated Access Technology™

TEL. (800) 852-6660

www.totaldoor.com

© Total Door 2013

FILE NAME

TDS33-03

DATE 4/20/12

# TECHNICAL DATA SHEET # 1 B

01

## PUSH-PULL MECHANISM - PART NAMES & NUMBERS

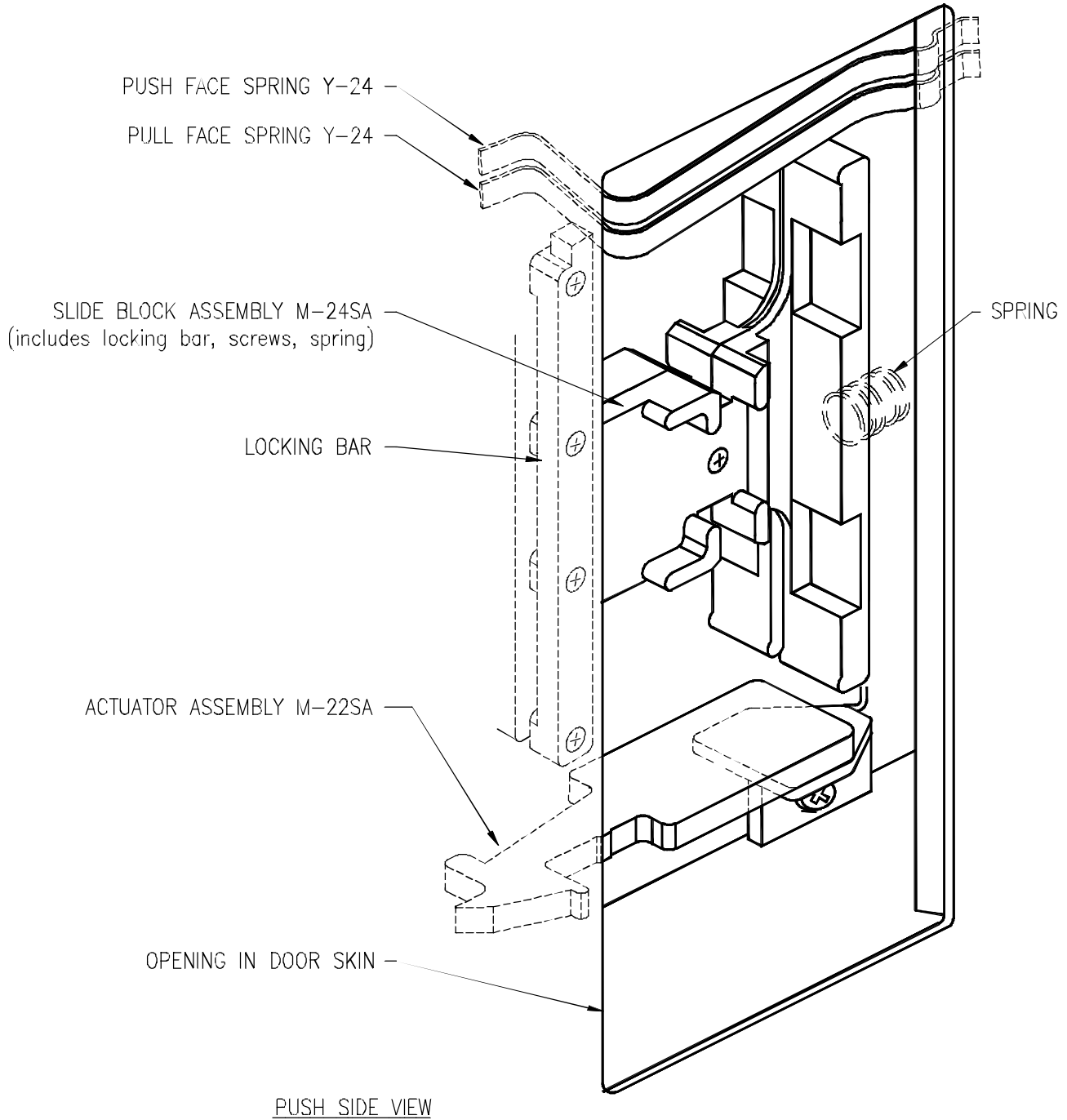

**Total Door** SYSTEMS™  
Global Leader in Integrated Access Technology™

TEL. (800) 852-6660

[www.totaldoor.com](http://www.totaldoor.com)

© Total Door 2013

FILE NAME

TDS1B-01

DATE 8/30/13



## LIMITED WARRANTY

This limited warranty covers the materials and workmanship of its products manufactured after March 1, 2017 for five (5) years from the ship date for interior applications and two (2) years from the ship date for exterior applications.

This limited warranty shall apply only if the product is properly stored, installed and maintained in accordance with Total Door Systems' published tolerances. Total Door Systems will, at its option, replace, repair or refund the purchase price paid to Total Door Systems for products which in its opinion, are found to be defective in workmanship or material under normal use and service within the above defined time periods. Total Door Systems' sole responsibility is as stated herein and it shall not be liable for consequential, indirect or incidental damages. \*Warranty replacement parts/components must be sent back to the factory for credit. An RA (return authorization) form must be requested when placing an order. Any and all warranty work must be handled through a certified distributor. Please contact Total Door Systems if assistance is need in locating a distributor.\*

This limited warranty is in place of all other warranties, express or implied, and excludes any warranties of fitness or merchantability. No agent, representative, dealer, or employee of Total Door Systems has the authority to increase or alter the obligations of this limited warranty.

### Notice Requirement

Purchaser is responsible for inspection of product upon receipt to ensure order is complete/accurate and provide notice of discrepancies to Total Door Systems within 30 days.

### Storage and Handling Instructions

1. Store Total Doors flat on a level surface in a dry, well ventilated building, separated by foam spacer blocks provided with original shipment so that no projecting hardware touches any part of an adjacent door.
2. Cover doors with opaque covering to keep clean and avoid discoloration. Cover must allow air circulation.
3. Steel doors with wood faces should not be subjected to extremes of heat and/or humidity conditions. Relative humidity should not be less than 30% or more than 60%.
4. Handle with clean gloves and do not drag doors across one another or across other surfaces.

### Installation

Total Doors must be installed in full compliance with manufacturer's published tolerances.

### Maintenance

To assure coverage under this limited warranty, the following must be maintained: the adjustment of hardware and fasteners attached to or fitted into the doors or frame, the finishes on all wood surfaces and the moisture protection on exterior doors.

### Exclusions

This limited warranty does not include:

- Total Doors that are not installed by a factory trained installer.
- Total Doors that are not installed to factory specified tolerances.
- Any products which, in the opinion of Total Door Systems, have been modified, repaired or altered in any way without the express written consent of the Company.
- Doors with cutouts for lights, louvers or other hardware nearer than six inches to the door edge, or doors with less than six inches between cutouts.
- Normal wear and tear including wear-through of finishes or deterioration for reasons other than material and workmanship.
- Items by other manufacturers and/or items supplied in the field.
- Wood surfaced doors exposed to relative humidity of less than 30% or greater than 60%.
- Field Painting of Hinge Verticals (H12, H13, H14 or H15).
- Field Paint of Locking Channel Verticals (L11).
- The appearance of field finished doors.
- The appearance of high gloss surfaced doors.
- Natural variations in the color or texture of wood.
- Custom finishes supplied by customer.
- Freight damage.
- Doors not stored per storage & handling instructions.

### Exclusions for Exterior Doors

An exterior door is one that cannot be controlled on both sides for temperature and humidity. The following conditions will void the limited warranty:

- Use of concealed closers.
- Wood faced doors.
- Doors and frames not properly protected by flashing or drip caps.
- Doors that are not sealed top and bottom.





TOTAL DOOR SYSTEMS®  
[www.totaldoor.com](http://www.totaldoor.com)

800.852.6660  
LIT0122-0913